

DIGITAL DRUM

Instruction Manual



Congratulations!

Thank you for purchasing this digital drum module. The drum module has been developed to act and play like a drum set but with greater ease. Before you use the instrument, we recommend you to read through this manual.

Taking Care of Your Digital Drum Set

Location

Do not expose the unit to the following conditions to avoid deformation, discoloration, or more serious damage.

- Direct sunlight.
- High temperature (near a heat source, or in a car during the day time).
- Excessive humidity.
- Excessive dust.
- Strong vibration

Power Supply

- Make sure to use the suitable AC adaptor, and also make sure the AC outlet voltage at your country matches the input voltage specified on the AC adaptor's label.
- Turn the power switch OFF when the instrument is not in use.
- An AC adaptor should be unplugged from the AC outlet if the instrument is not be used for an extended period of time.
- Unplug the AC adaptor during electric storms.
- Avoid plugging the AC adaptor into the same AC outlet as appliance with high power consumption, such as electric heaters or ovens. Also avoid using multi-plug adaptors since these can result in reducing the sound quality, operation errors, and possibly damage.

Radiated Immunity

- The normal function of the product may be disturbed by Strong Electro Magnetic Interference. If so, simply reset the product to resume normal operation by following the instruction manual. In case the function could not resume, please use the product in other location.
- ESD, Fast Transient and Surge may cause the unit to temporary malfunction. Switch off and on again to resume normal operation.

Handling and Transport

- Never apply excessive force to the controls, connectors or other parts of the instrument.
- Always unplug cables by gripping the plug firmly, but not pulling on the cable.
- Disconnect all cables before moving the instrument.
- Physical shocks caused by dropping, bumping, or placing heavy objects on the instrument can result in scratches and more serious damage.

Cleaning

- Clean the unit with a dry soft cloth.
- A slightly damp cloth may be used to remove stubborn grime and dirt.
- Never use cleaners such as alcohol or thinner.
- Avoid placing vinyl object on top of the unit (vinyl can stick to and discolor the surface).

Electrical Interference

This instrument contains digital circuitry and may cause interference if placed too close to radio or television receivers. If this occurs, move the instrument further away from the affected equipment.

Turn Power OFF When Making Connections

To avoid damage to the instrument and other devices to which it is connected, turn the power switches of all related device OFF prior to connecting or disconnecting cables.

THIS DEVICE COMPLIES WITH PART 15 OF THE FCC RULES. OPERATION IS SUBJECT TO THE FOLLOWING TWO CONDITIONS:
(1) THIS DEVICE MAY NOT CAUSE HARMFUL INTERFERENCE, AND
(2) THIS DEVICE MUST ACCEPT ANY INTERFERENCE RECEIVED, INCLUDING INTERFERENCE THAT MAY CAUSE UNDESIRE OPERATION.

Contents

Panel Controls	4
- Front Panel	4
- Rear Panel	5
Setup	6
- Connect the Pads and the Pedals	6
- Connect the Power supply jack	7
- Connect a audio equipment	7
- Connect a CD player, etc.(Mix in jack)	7
- Connect Headphones	7
- Connect a MIDI and USB device	8
- MIDI out format	8
Functions	9
- Switch the power ON	9
- Set the main volume	9
- Select a drum kit	9
- Adjust the kit volume	9
- Select a pad voice	10
- Adjust the pad volume	10
- Save kit	10
- Select a pattern	11
- Listen to the pattern	11
- Adjust the pattern volume	11
- Recording	12-13
- Drum off	13
- Adjust the pattern tempo	14
- Click	14
- Select a click sound	14
- Adjust the click volume	15
- Factory reset	15
- Hi-Hat control	15
Specifications	16
Voice list	17
Pattern list	18
Percussion Set List	19
MIDI implementation chart	20

Panel Controls

Front Panel

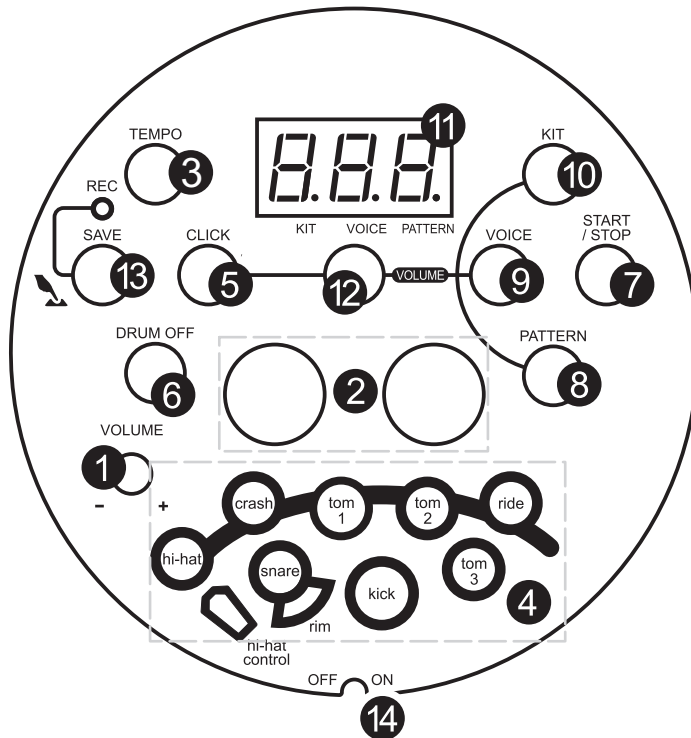

- 1 [volume] knob**
Control the volume of phone.
Turn it clockwise to increase the volume and anticlockwise to decrease it.
- 2 [+] and [-] buttons**
Adjust the parameter of the current menu (KIT, voice, pattern, click value, tempo value, etc.).
- 3 [tempo] Button**
Enter the tempo adjustment mode.
- 4 Pads indicators**
It shows the trigger sound in process of pattern play.
- 5 [click] Button and indicator**
Turn on or off the metronome.
- 6 [drum off] Button and indicator**
It is used to mute on or mute off the drum part of the song.
- 7 [start/stop] Button**
Start or stop song playing.
- 8 [pattern] Button**
Enter the pattern select mode and provide MIDI output format choice.
- 9 [voice] Button**
Enter the voice select mode.
- 10 [kit] Button**
Enter the kit select mode.
- 11 3-digit LED**
Display the parameters of current menu .
- 12 [volume] Button**
Enter the volume adjustment mode and to separately adjust the kit volume, voice volume, click volume and pattern volume.
- 13 [save/rec] Button**
Afford two modes:
Short pressing [save/rec] button to save the current kit setting to a user kit.
Press and hold on [save/rec] button to enter recording mode.
- 14 Power Switch**
Turn the power on or off .

Rear Panel

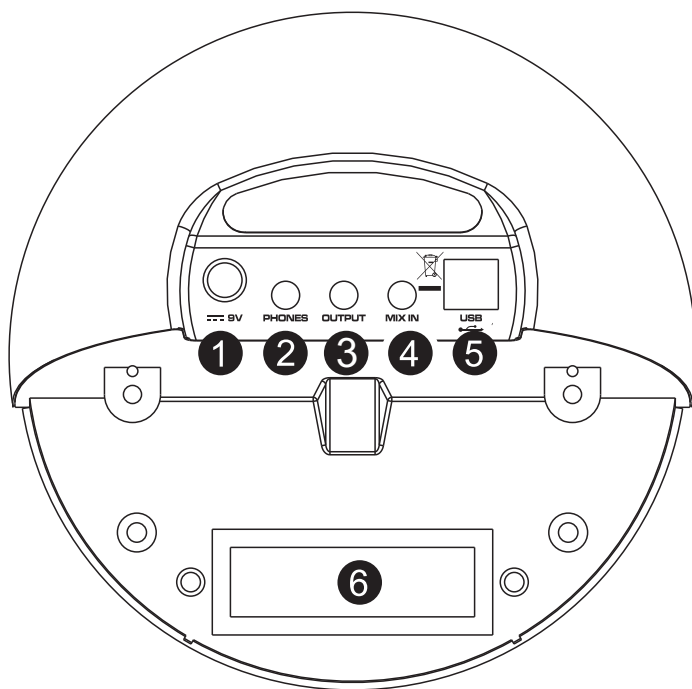

- 1 DC Input**
Support DC 9V power.
- 2 Phone Jack**
Connect headphone or loudspeaker.
- 3 Output Jacks**
Support Line stereo output.
- 4 MIX Input Jacks**
Connect with external sound source.
- 5 USB Port**
Connect to computer or other USB host devices.
- 6 Trigger Input Jacks**
Connect with kick, snare, tom1~tom3, ride, crash, hi-hat, hi-hat control triggers.

Setup

Caution!

To prevent electric shock and damage to the device, make sure the power is switched OFF on the drum and all related device before making any connection.

Connect the Pads and the Pedal

Using the provided cables, connect with kick, snare, tom1~tom3, ride, crash, hi-hat, hi-hat control triggers. Snare is stereo input, supports double triggering (increase edge triggering); cymbal (includes ride and crash) kick, tom, Hi-Hat are mono input, which can't response edge triggering. Hi-Hat pedal is stereo input.

Note:

1. The voice of hi-hat pad hitting is controlled by hi-hat pedal. Similar to a real drum kit, the hi-hat pad functions as an 'open hi-hat' when the pedal is released. When the pedal is stepped, it functions as a 'closed hi-hat' .
2. The valid striking area of a cymbal pad (ride, crash or hi-hat) is half part of the pad on the player side, which is different from other pads.

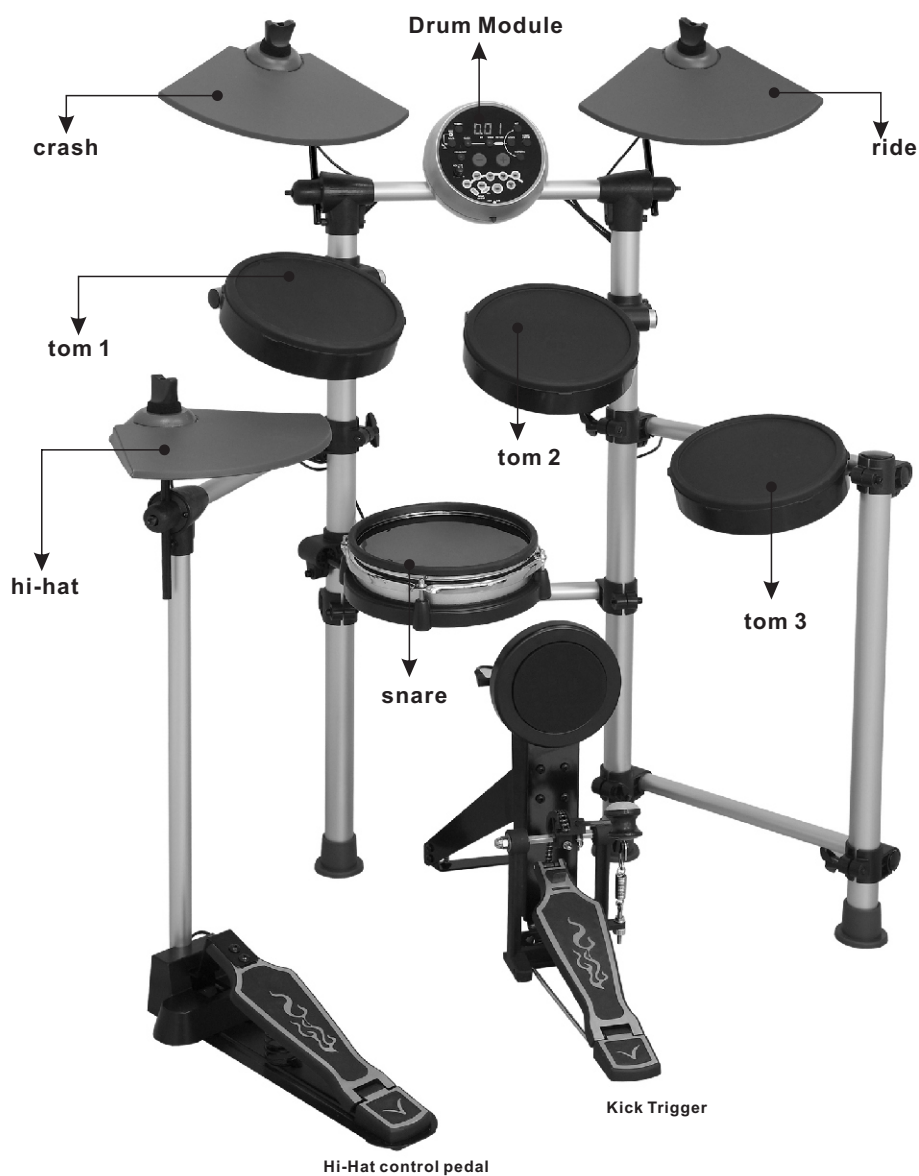

Connect the Power supply jack

Make sure the power is switched OFF and connect the power adaptor with the DC jack on the rear panel.

Note:

1. To protect the speakers, amplifier and the drum module from damage, rotate the volume knob to the minimum volume level before switching the power ON.
2. Make sure the power is switched OFF when connecting drum module with external devices.

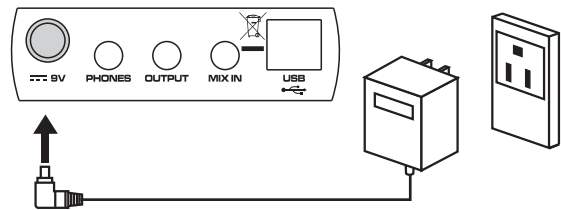

Connect a audio equipment

When you want to listen to the voices with an amplifier, connect amplifiers with the Output jacks on the rear panel.

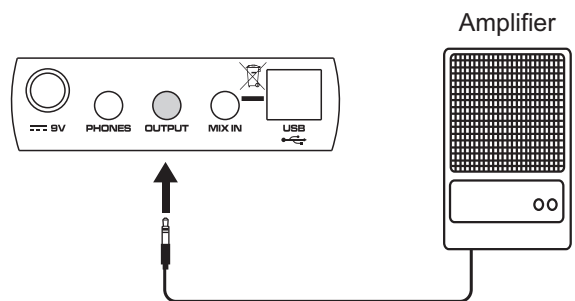

Connect a CD player, etc.(Mix. In jack)

The audio output of a CD player, or other audio source, to connect with the MIX IN jack on the rear panel can be mixed with the sound of the drum. This function is convenient that let you play along with a favourite song.

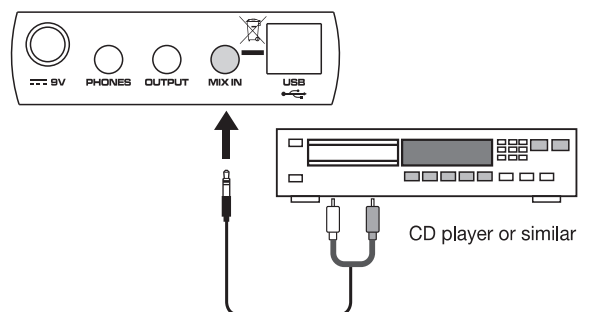

Connect Headphones

An optional set of stereo headphones can be connected with the PHONES jack located on the rear of the drum module.

* Adjust the volume to a comfortable level.

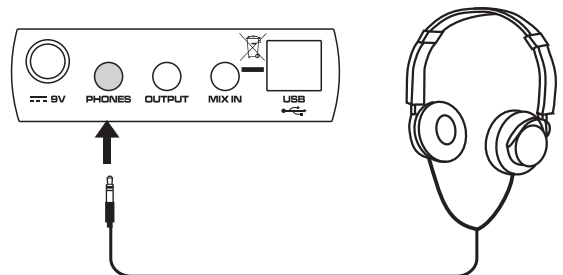

Functions

Switch the power ON

After confirming all connection have been completed, rotate the volume knob to the left (minimum volume level) before switching the power on.

Set the power switch to "on" position to switch on the power. Display shows the kit's number and its indicator lights up.



Set the main volume

While hitting a pad, gradually rotate the volume knob until a comfortable volume level is reached.

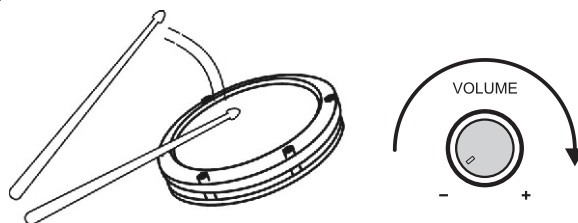

Select a drum kit

The unit comes with 10 (001-010) preset drum kits and 5 user kits (011-015).

Press [kit] button to enter KIT selecting mode, 3-digit LED displays the current KIT number and KIT indicator lights up.

In kit selecting mode, press [+] or [-] button to choose any KIT(001-015,in cycle) as the current KIT.

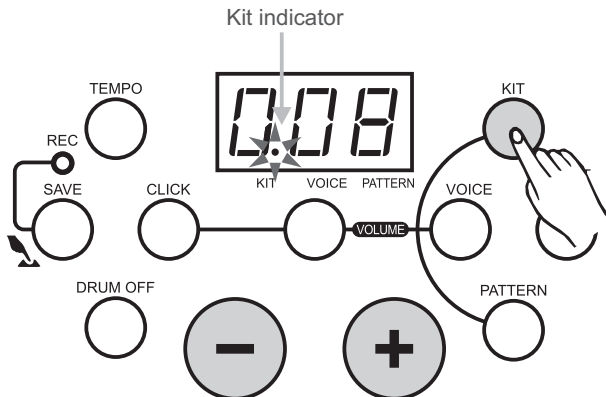

Adjust the kit volume

In KIT selecting mode, press [volume] button to enter volume adjusting mode, volume indicator lights, 3-digit LED displays the current kit volume value, adjust its value by pressing [+] and [-] button. (0-16, not in cycle); Then press [kit] button again to enter KIT selecting mode and volume indicator off.

Be note that in recording waiting mode, the KIT volume value could be shown on LED but it could not be adjusted.

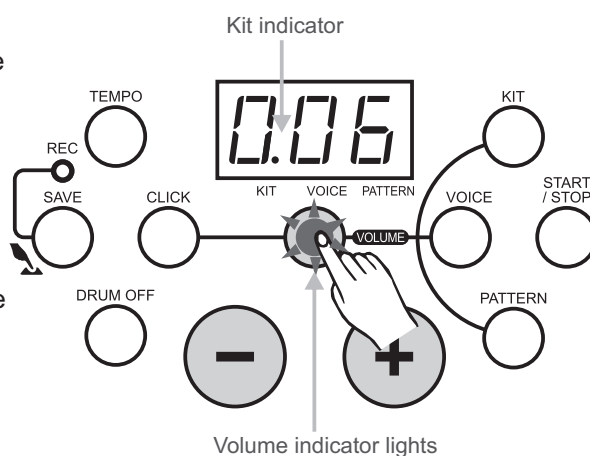

Select a pad voice

It provides 108 built-in drum voices in all to choose.

Press [voice] button to enter pad voice selecting mode, 3-digit LED displays the current pad voice number and voice indicator lights.

In the pad voice selecting mode, press [+] and [-] button to choose the voice of current pad or cymbal (1-108, in cycle).

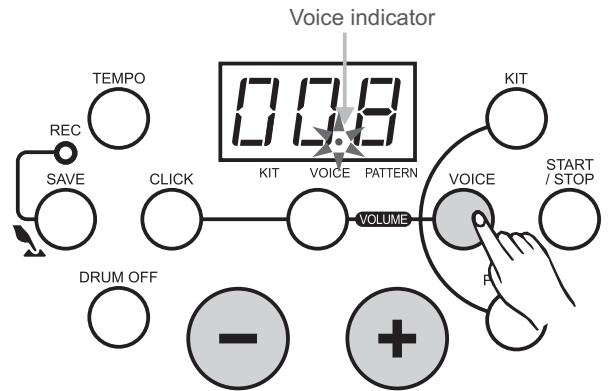

Adjust the pad volume

In voice selecting mode, press [volume] button to enter pad volume adjusting mode, volume indicator lights, 3-digit LED displays the current pad volume value.

Press [+] and [-] button to adjust its value (0-16, not in cycle).

Press [voice] button again to enter voice selecting mode.

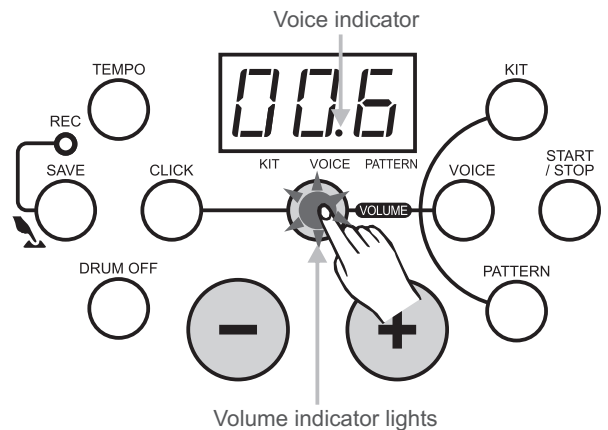

Save kit

Press [save] button to enter KIT saving mode, 3-digit LED displays the user KIT number to save, KIT indicator lights and user KIT number flash.

Press [+] and [-] button to choose the user KIT (11-15, in cycle) to save. During choosing the KIT, the user KIT number will be kept flashing.

Press [save] button again, the current KIT setting (includes all pads voice numbers and volume) is saved into the chosen user KIT.

When in recording mode, the user are not allowed to use this function.

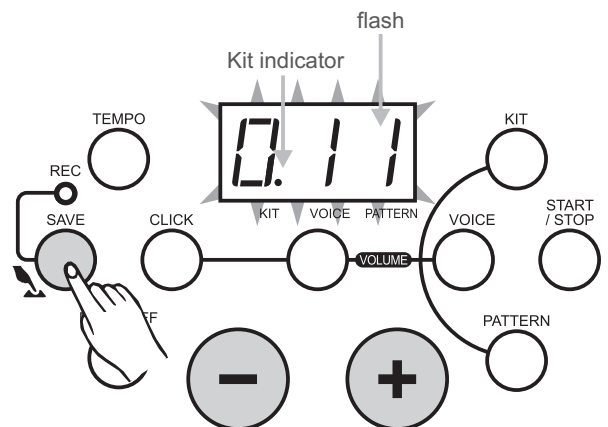

Select a pattern

It offer 41 built-in patterns (40 preset patterns and one user pattern).

Press [pattern] button to enter pattern choice mode, 3-digit LED displays the current pattern number and pattern indicator lights.

Press [+] and [-] button to choose the current pattern number (1-41, in cycle).

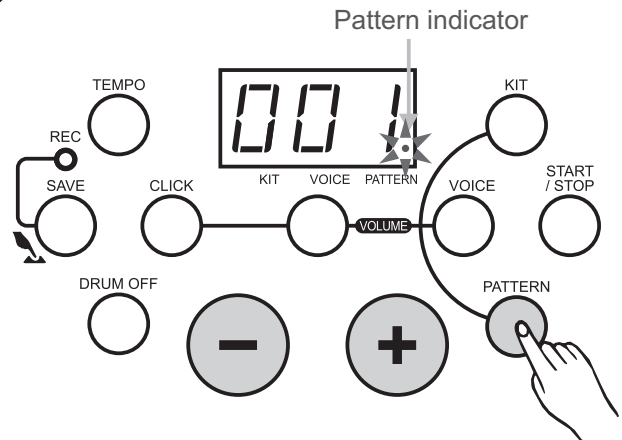

Listen to the pattern

Press [start/stop] button to start/stop pattern playing. In process of pattern playing, click indicator lights and flash, which shows the beat of the playing pattern, and the pad indicators lights in accompany with the variable trigger sound in process of pattern play, for easy learning and practsing. If another pattern be selected in current song playing, it will start to play at the next measure.

In pattern playing mode, press [start/stop] button to stop pattern play.

Note:

The pattern and the MIDI IN use the same 16 midi channels, when you use MIDI IN to play a song, it maybe affect the built-in pattern playing. So you must reset the drum module.

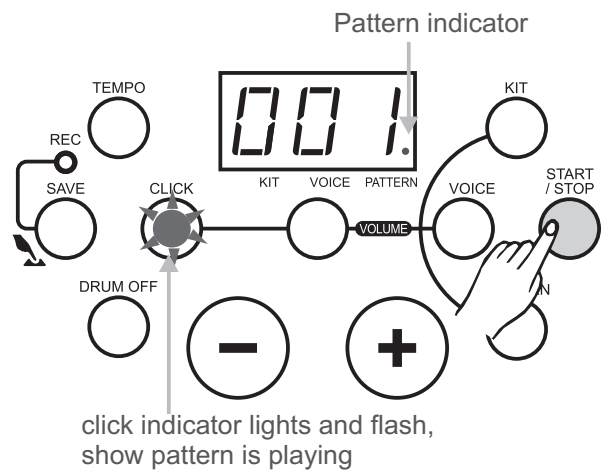

click indicator lights and flash, show pattern is playing

Adjust the pattern volume

In pattern choice mode, press [volume] button to enter pattern volume adjusting mode, 3-digit LED displays the accompaniment volume value of current pattern (be note that the percussion part volume can not be adjusted, it just could be mute on/off by using [drum off] button), and volume indicator lights, press [+] and [-] button to adjust pattern volume value (0-16, not in cycle). Then press [pattern] button again to enter pattern choice mode.

Be note that in recording waiting mode, the pattern volume value could be shown on LED but it could not be adjusted.

Note:

pattern volume only control the accompaniment part volume of the pattern.

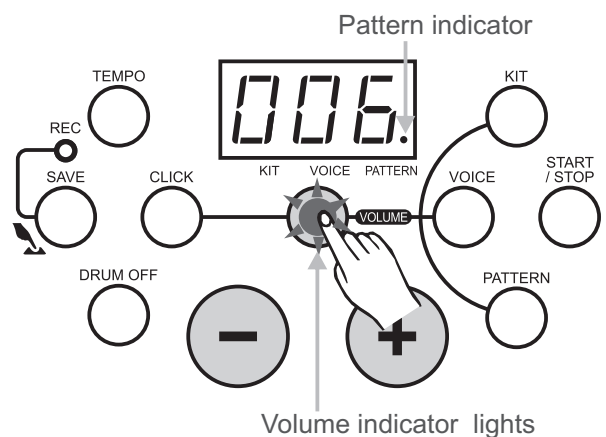

Recording

Enter the Recording Waiting Mode

Press and hold [save] button more than 2 seconds, to enter user pattern recording waiting mode, 3-digit LED displays KIT number and REC indicator flashes. In recording waiting mode, the correspondent parameter can be adjusted.

- Adjust pattern number as accompaniment.
- Adjust tempo value.
- Adjust KIT number.
- Switch drum off status.
- Turn on/off click

In the Recording Waiting Mode, press [pattern] to show the pattern (---~001~040) as accompaniment for recording. Use [+] or [-] to select the accompaniment, if "---" be selected, that means the user would like to record a solo drum part.

Note:

VOICE selecting function are not allowed for user in recording waiting mode and time signature.

Enter Recording Mode

Press [start/stop] button or hit pads to enter recording mode, then REC indicator lights all along, 3-digit LED displays recording measures.

- During recording, the original data will be covered with the newly recorded user pattern.
- One measure introductory beat (such as 4/4, display: -4, -3, -2, -1).
- All parameter could not be adjusted in process of recording. Only "START/STOP" and "CLICK" button are valid during recording.
- Click would not be recorded.

Stop Recording

When recording is full, it will automatically stop recording, and REC indicator goes out, 3-digit LED displays 'ful', then press [start/stop] button to returns to NO.41 PATTERN display.

During recording, if press [start/stop] button, it will stop recording, REC indicator goes out, then it returns to NO.41 PATTERN display.

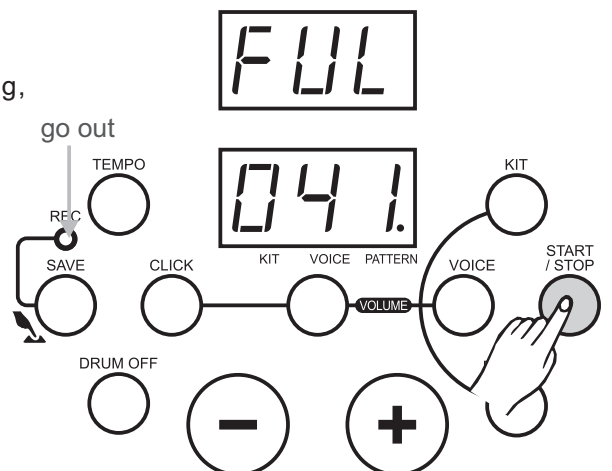
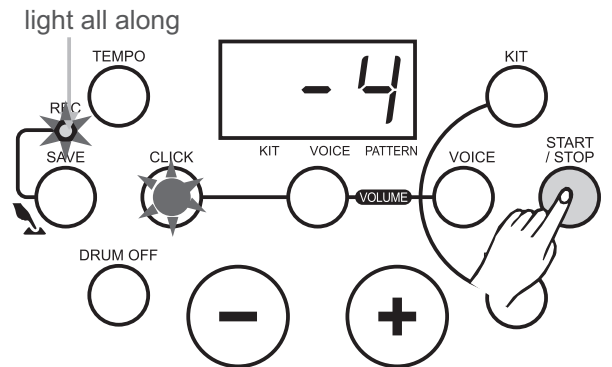
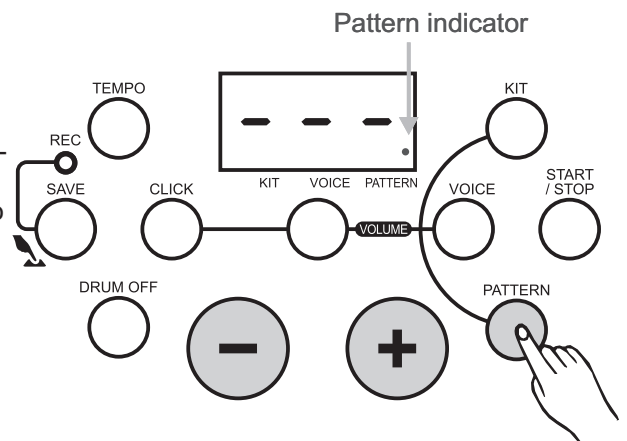
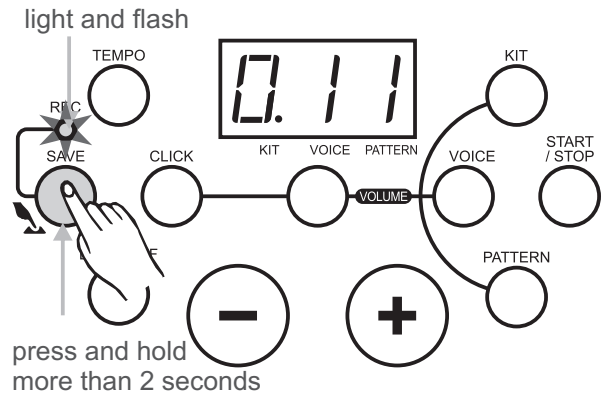

Playback User Pattern

Choose the pattern number 41, press [start/stop] button to play user pattern.

- If there is no recording data, 3-digit LED displays "N-P".
- The user are allowed to change pattern volume and tempo value when playing user pattern.
- Response pads operations realistically.
- No measures displayed on LED.
- It plays the user pattern not in cycle
- When using [Drum off] button, it just mute the drum part of the accompaniment and will not mute the recorded part.
- Pattern volume and Kit volume only control the corresponding part of the accompaniment.

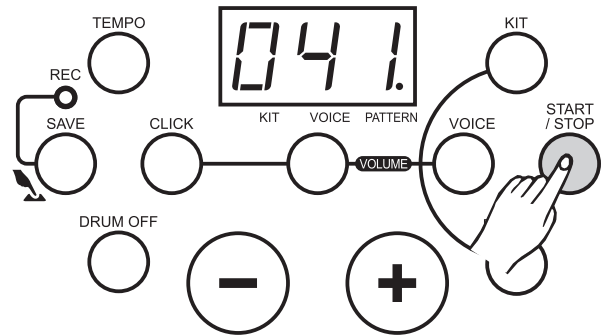

Note:

If the user selecting another kit when playing the user pattern, the recorded kit data will also be changed to the current selected kit.

Recording notes

The recording capacity is about 5000 notes.

Quick recording

After choosing a favorite KIT and adjusting the parameter well,(includes tempo, click), the user could easily press and hold [save] button to enter recording waiting mode, then hit pads or press [start/stop] button to start recording.

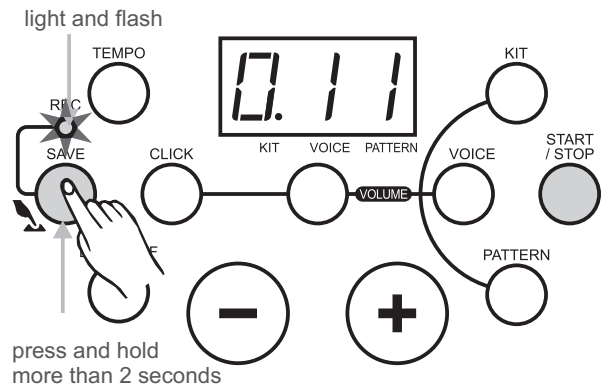

Drum off

Press [drum off] button to mute on/off the drum part. If "drum off" activated, the drum sound of the current playing pattern will be muted and "drum off" indicator lights. This function is convenient for user practise.

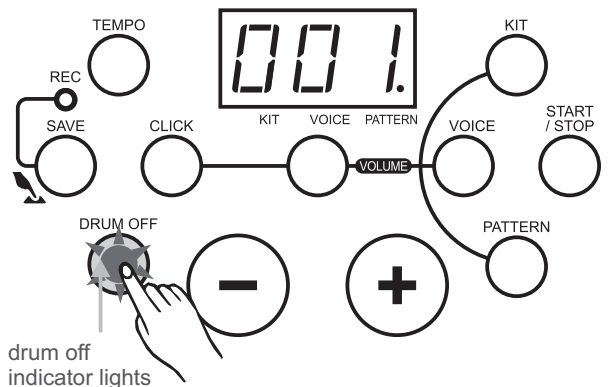

Adjust the pattern tempo

Press [tempo] button to enter tempo adjustment mode, 3-digit LED temporarily displays TEMPO value.

Press [+] and [-] button to change the tempo of click and pattern playing (30-280, not in cycle).

Press [+] and [-] button at the same time, to reset to the default value (the current pattern default tempo).

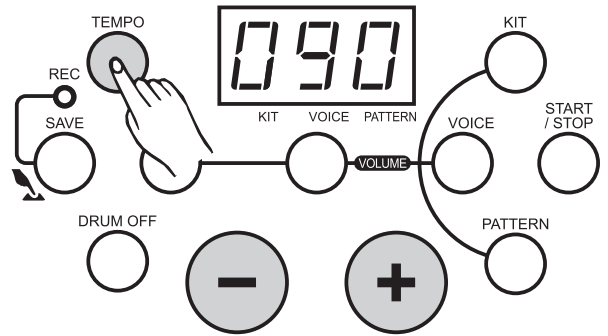

Click

Press [click] button to turn on/off click, 3-digit LED displays the current time signature, and the click indicator lights and flash, press [+] and [-] button to change the current time signature. Press [click] button again to turn off click.

9 kinds of time signature can be chosen (1/4, 2/4, 3/4, 4/4, 5/4, 6/4, 7/4, 3/8, 6/8)

As pattern playing, the click indicator automatically flash according the pattern beat, but the click sound will not be turned on automatically.

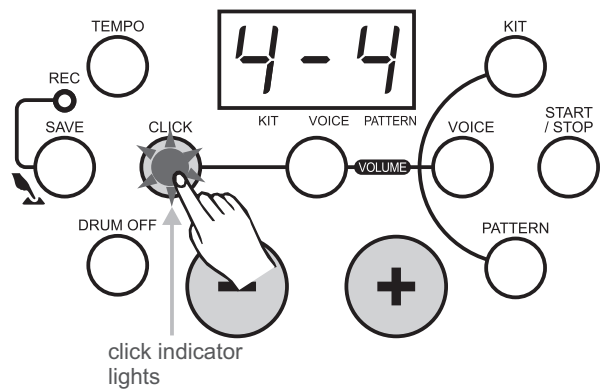

Select a click sound

Press and hold [click] button, then press [+] or [-] button to adjust the click sound, 3-digit LED temporarily displays the current click sound 'CLX'.

The drum module supports 4 click sounds: metronome, beep, cowbell and voice. When turn on the click, the default sound is "metronome".

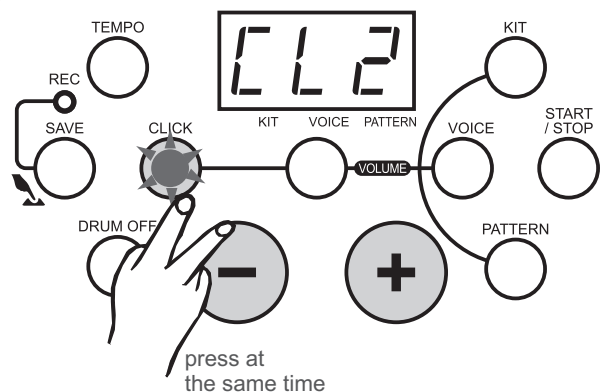

Adjust the click volume

In click time signature choice mode, press [volume] button to enter click volume adjusting mode, volume indicator lights, 3-digit LED displays the click current volume value; Its volume value can be, adjusted by pressing [+] and [-] button (0-16 not in cycle).

Return click time signature choice mode

In click volume adjusting mode, press [click] button to exit volume adjusting mode, return to click time signature choice mode.

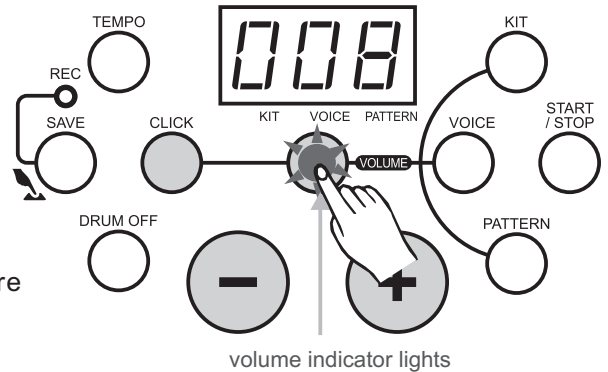

Factory reset

Press [+] and [-] button at the same time to turn on the drum module, it resets to factory setting. The following data will be replaced to the factory data:
All users kits (include voice, volume setting).
Clear recording data.

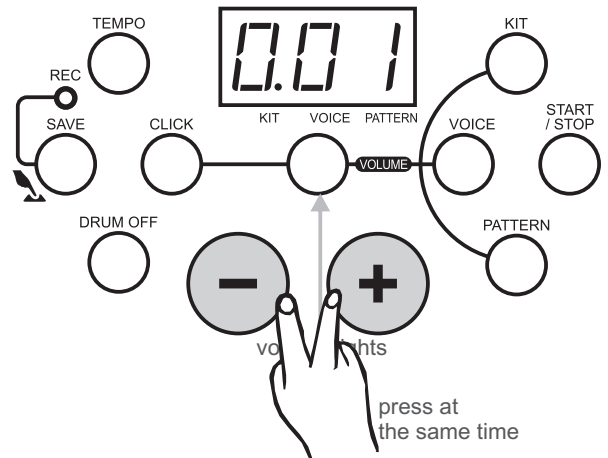

Hi-Hat control

- **Open Hi-Hat:** Strike the hi-hat without stepping the pedal.
- **Closed Hi-Hat:** Strike the hi-hat with the pedal stepped.
- **Foot Closed:** Completely step down the pedal.
- **Splash:** play the hi-hat with the pedal fully stepped and then instantly releasing it.



Specifications

Drum Pad:	3 tom pads , 2 cymbal pads ,1 snare pad(dual trigger), 1 hi-hat control pedal , 1 hi-hat, 1 kick
Voices:	108 voices
Drum kits:	10 preset kits, 5 user kits
Patterns:	40 preset songs and 1 user pattern
Controls:	POWER SWITCH, START/STOP, SAVE/RECORD, KIT, PATTERN, VOICE, KIT/VOICE/PATTERN/CLICK VOLUME, DRUM OFF, CLICK, HI-HAT, CRASH, RIDE, HI-HAT CONTROL, SNARE, TOM 1, TOM 2, TOM3, KICK, RECORD LIGHT, VOLUME + / -, TEMPO, +/-
Display:	LED display
Connections:	PHONES USB OUTPUT MIX IN DC POWER Hi-hat control Hi-hat Crash Ride Snare Tom 1 Tom 2 Tom 3 Kick
Power Supply:	AC adaptor (≡ 9V)

Voice List

No.	NAME
-----	------

KICK

001	Standard Kick 1
002	Standard Kick 2
003	Classic Kick 1
004	Classic Kick 2
005	Rock Kick
006	Camco Kick 1
007	Camco Kick 2
008	Acoustic Kick 1
009	Acoustic Kick 2
010	Acoustic Kick 3
011	Acoustic Kick 4
012	TR606 Kick

SNARE

013	Standard Snare
014	Standard Snare Rim
015	Funk Snare
016	Funk Snare Rim
017	Funk Stick
018	Classic Snare
019	Classic Snare Rim
020	Rock Snare
021	Rock Snare Rim
022	Brush Snare
023	Brush Snare Rim
024	Camco Snare
025	Camco Snare rim
026	TR606 Snare

TOM

027	Classic Tom 1
028	Classic Tom 2
029	Classic Tom 3
030	Classic Tom 4
031	Classic Tom 5
032	Classic Tom 6
033	Rock Tom 1
034	Rock Tom 2
035	Rock Tom 3

No.	NAME
-----	------

036	Rock Tom 4
037	Rock Tom 5
038	Rock Tom 6
039	Brush Tom 1
040	Brush Tom 2
041	Brush Tom 3
042	Brush Tom 4
043	Brush Tom 5
044	Brush Tom 6
045	Camco Tom 1
046	Camco Tom 2
047	Camco Tom 3
048	Camco Tom 4
049	Camco Tom 5
050	Camco Tom 6
051	TR606 Tom 1
052	TR606 Tom 2
053	TR606 Tom 3
054	TR606 Tom 4
055	TR606 Tom 5
056	TR606 Tom 6

RIDE

057	Classic Ride
058	Rock Ride
059	Brush Ride
060	TR606 Ride

CRASH

061	Classic Crash
062	Rock Crash 1
063	Rock Crash 2
064	Brush Crash
065	China Crash
066	TR606 Crash

HIHAT

067	Classic Open Hi hat
068	Rock Open Hi hat
069	TR606 Open Hi hat

No.	NAME
-----	------

Percussion

070	Tabla 001
071	Tabla 002
372	Tabla 003
073	Tabla 004
074	Tabla 005
075	Tabla 006
076	Bongo High
077	Bongo Low
078	Conga 1
079	Conga 2
080	Conga 3
081	Timbale High
082	Timbale Low
083	Agogo High
084	Agogo Low
085	Cowbell 1
086	Cowbell 2
087	Cowbell 3
088	Cowbell 4
089	Cowbell 5
090	Cowbell 6
091	Cowbell 7
092	Cowbell 8
093	Cowbell 9
094	Cowbell 10
095	Hi Hat 001
096	Hi Hat 002
097	Hi Hat 003
098	Hi Hat 004
099	Hi Hat 005
100	Hi Hat 006
101	Hi Hat 007
102	Hi Hat 008
103	Hi Hat 009
104	Dj001
105	Dj002
106	Dj003
107	Dj004
108	Dj005

Preset KIT and Default user KIT

No.	KIT
-----	-----

001	Standard
002	Rock
003	Pop
004	Funk
005	Brush
006	Jazz
007	Table
008	Latin

No.	KIT
-----	-----

009	TR606
010	DJ
011	User kit1 (Standard)
012	User kit2 (Rock)
013	User kit3 (Pop)
014	User kit4 (Funk)
015	User kit5 (Brush)

Note:

Number 001~010 are preset kits, number 011~015 are users kits.

Pattern List

No.	PATTERN
-----	---------

001	Fusion1
002	Latin Jazz1
003	Funk1
004	Latin Pop1
005	60's Rock
006	Big Band1
007	Drum N'Bass
008	Ballad
009	Swing
010	Pop1
011	Funk2
012	Latin Jazz2
013	Pop Funk1
014	Latin Rock1
015	Big Band2
016	Pop Ballad
017	Pop Funk2
018	3/4Jazz
019	Pop Bossa
020	Samba1
021	6/8Ballad

No.	PATTERN
-----	---------

022	Fusion2
023	Jazz1
024	Guitar Bossa
025	Break Beat
026	World1
027	Funk3
028	Latin Jazz3
029	Latin Pop2
030	Reggae1
031	World2
032	Latin
033	Bossa
034	Samba2
035	3/4Pop
036	Pop2
037	Jazz2
038	Reggae2
039	Reggae3
040	Latin Rock2
041	User Pattern

Percussion Set List

Standard(PC0)	Rock(PC1)	Pop(PC2)	Funk(PC3)	Brush(PC4)	Jazz(PC5)	606(PC6)	DJ(PC7)
27 High Q	<-	<-	<-	<-	<-	<-	<-
28 Slap	<-	<-	<-	<-	<-	<-	<-
29 Scratch Push	<-	<-	<-	<-	<-	<-	<-
30 Scratch Pull	<-	<-	<-	<-	<-	<-	<-
31 Sticks	<-	<-	<-	<-	<-	<-	<-
32 Square Click	<-	<-	<-	<-	<-	<-	<-
33 Metronome Click	<-	<-	<-	<-	<-	<-	<-
34 Metronome Bell	<-	<-	<-	<-	<-	<-	<-
35 STD Kick 2	<-	<-	<-	<-	<-	<-	<-
36 STD Kick 2	Rock Kick	Pop Kick	Funk Kick	Brush Kick	Jazz Kick	TR606 Kick	<-
37 Side Stick	<-	<-	<-	<-	<-	<-	<-
38 STD Snare	Rock Snare	Pop Snare Drum	Funk Snare	Brush Snare	Jazz Snare	TR606 Snare	<-
39 Hand Clap	<-	<-	<-	<-	<-	<-	<-
40 STD Snare Rim	Rock Snare Rim	Pop Snare Rim	Funk Snare Rim	Brush Snare Rim	Jazz Snare Rim	TR606 Snare Rim	<-
41 STD Low Tom 2	Rock Low Tom 2	Pop Low Tom 2	Funk Low Tom 1	Brush Low Tom2	Jazz Low Tom 2	TR606 Low Tom 2	<-
42 Closed Hi-Hat	<-	<-	<-	<-	<-	TR606 Closed Hi-Hat	<-
43 STD Low Tom 1	Rock Low Tom 1	Pop Low Tom 1	Funk Low Tom 1	Brush Low Tom 1	Jazz low tom 1	TR606 Low Tom1	<-
44 Pedal Hi-Hat	<-	<-	<-	<-	<-	TR606 Pedal Hi-Hat	<-
45 STD Mid Tom 2	Rock Mid Tom 2	Pop Mid Tom 2	Funk Mid Tom 2	Brush Mid Tom 2	Jazz Mid Tom 2	TR606 Mid Tom 2	Dj Mix 5
46 Open Hi-Hat	<-	<-	<-	<-	<-	TR606 Open Hi-Hat	<-
47 STD Mid Tom 1	Rock Mid Tom 1	Pop Mid Tom 1	Funk Mid Tom 1	Brush Mid Tom 1	Jazz Mid Tom 1	TR606 Mid Tom 1	Dj Mix 4
48 STD Hi Tom 2	Rock Hi Tom 2	Pop Hi Tom 2	Funk Hi Tom 2	Brush Hi Tom 2	Jazz Hi Tom 2	TR606 Hi Tom 2	Dj Mix 3
49 Crash Cymbal 1	<-	<-	<-	<-	<-	tr606 crash cymbal1	Dj Mix 2
50 STD Hi Tom 1	Rock Hi Tom 1	Pop Hi Tom 1	Funk Hi Tom 1	Brush Hi Tom 1	Jazz Hi Tom 1	TR606 Hi Tom 1	<-
51 Standard Ride	Rock Ride	<-	<-	Brush Ride	<-	<-	Dj Mix 1
52 Chinese Cymbal	<-	<-	<-	<-	<-	<-	<-
53 Ride Bell	<-	<-	<-	<-	<-	<-	<-
54 Tambourine	<-	<-	<-	<-	<-	<-	<-
55 Splash Cymbal	<-	<-	<-	<-	<-	<-	<-
56 Cowbell	<-	<-	<-	<-	<-	<-	<-
57 Crash Cymbal 2	<-	<-	<-	<-	<-	<-	<-
58 Vibraslap	<-	<-	<-	<-	<-	<-	<-
59 Ride Cymbal 2	<-	<-	<-	<-	<-	<-	<-
60 Hi Bongo	<-	<-	<-	<-	<-	<-	<-
61 Low Bongo	<-	<-	<-	<-	<-	<-	<-
62 Mute Hi Conga	<-	<-	<-	<-	<-	<-	<-
63 Open Hi Conga	<-	<-	<-	<-	<-	<-	<-
64 Low Conga	<-	<-	<-	<-	<-	<-	<-
65 High Timbale	<-	<-	<-	<-	<-	<-	<-
66 Low Timbale	<-	<-	<-	<-	<-	<-	<-
67 High Agogo	<-	<-	<-	<-	<-	<-	<-
68 Low Agogo	<-	<-	<-	<-	<-	<-	<-
69 Cabasa	<-	<-	<-	<-	<-	<-	<-
70 Maracas	<-	<-	<-	<-	<-	<-	<-
71 Short Whistle	<-	<-	<-	<-	<-	<-	<-
72 Long Whistle	<-	<-	<-	<-	<-	<-	<-
73 Short Guiro	<-	<-	<-	<-	<-	<-	<-
74 Long Guiro	<-	<-	<-	<-	<-	<-	<-
75 Claves	<-	<-	<-	<-	<-	<-	<-
76 Hi Wood Block	<-	<-	<-	<-	<-	<-	<-
77 Low Wood Block	<-	<-	<-	<-	<-	<-	<-
78 Mute Cuica	<-	<-	<-	<-	<-	<-	<-
79 Open Cuica	<-	<-	<-	<-	<-	<-	<-
80 Mute Triangle	<-	<-	<-	<-	<-	<-	<-
81 Open Triangle	<-	<-	<-	<-	<-	<-	<-
82 Shaker	<-	<-	<-	<-	<-	<-	<-
83 Jingle Bell	<-	<-	<-	<-	<-	<-	<-
84 Belltree	<-	<-	<-	<-	<-	<-	<-
85 Castanets	<-	<-	<-	<-	<-	<-	<-
86 Mute Surdo	<-	<-	<-	<-	<-	<-	<-
87 Open Surdo	<-	<-	<-	<-	<-	<-	<-

<-: Same as the left one.

MIDI Implementation Chart

Function		Transmitted	Recognized	Remarks
Basic	Default	10 ch	1-16	
Channel	Changed	X	X	
Mode	Default	X	X	
	Messages	X	X	
	Altered	*****	*****	
Note		0 - 127	0 - 127	
Number:	True voice	*****	0 - 127	
Velocity	Note on	O 99H, V=1-127	O	
	Note off	O (99H, V=0)	O	
After	Key's	X	X	
Touch	Channel's	X	X	
Pitch	Bend	X	O	
Control	0	X	O	Bank Select
Change	1	X	O	Modulation
	5	X	O	Portamento Time
	6	X	O	Data Entry
	7	X	O	Volume
	10	X	O	Pan
	11	X	O	Expression
	64	X	O	Sustain Pedal
	65	X	O	Portamento ON/OFF
	66	X	O	Sostenuto Pedal
	67	X	O	Soft Pedal
	80	X	O	Reverb Program
	81	X	O	Chorus Program
	91	X	O	Reverb Level
	93	X	O	Chorus Level
	120	X	O	All Sound OFF
	121	X	O	Reset All Controller
	123	X	O	All Notes OFF
Program	Change	O	O	
System	Exclusive	X	O	
System	: Song Position	X	X	
Common	: Song Select	X	X	
	: Tune	X	X	
System	: Clock	X	X	
RealTime	: Commands	X	X	
Aux	: Local ON/OFF	X	X	
	: All Notes OFF	X	O	
Messages	: Active Sense	O	X	
	: Reset	X	X	

Note 1: Reverb program vv=00H to 07H (default 04H)

00H : Room1 01H : Room2
 02H : Room3 03H : Hall1
 04H : Hall2 05H : Plate
 06H : Delay 07H : Pan delay

Note2: Chorus program vv=00H to 07H (default 02H)

00H : Chorus1 01H : Chorus2
 02H : Chorus3 03H : Chorus4
 04H : Feedback 05H : Flanger
 06H : Short delay 07H : FB delay

Note3: Just respond 3 type of RPN 000~002.

O : YES X : NO

