

User's Manual

# DIGITAL PIANO

---

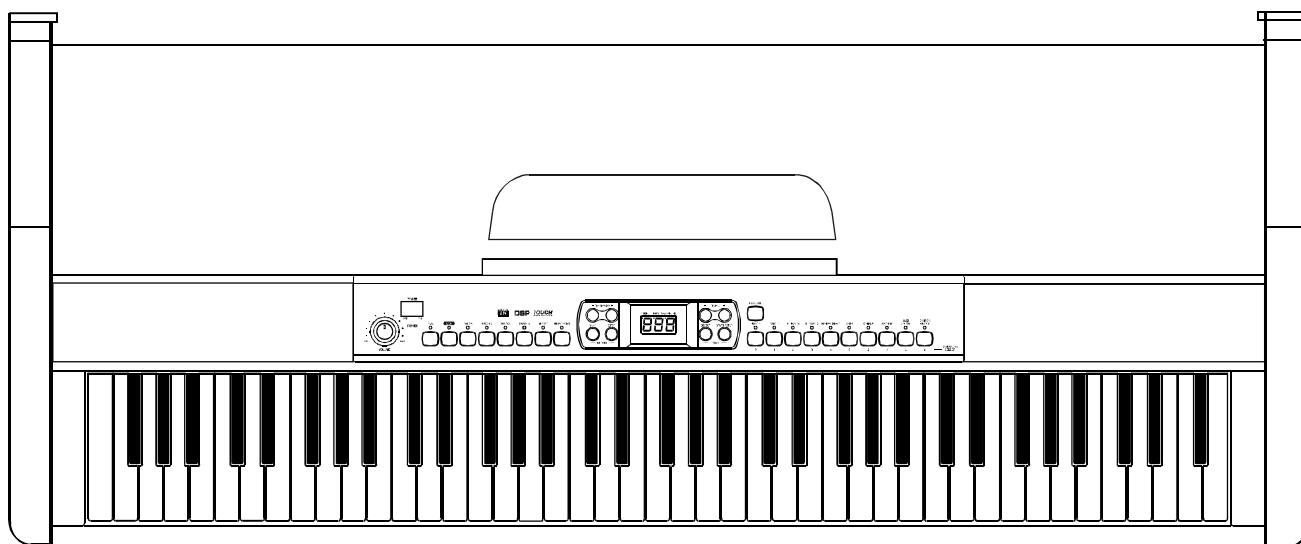

# Using the Instruction Manual

Thank you for purchasing this Digital Piano. The use of high technology and the most advanced sampling technique brings you high quality sound and enjoyment. The combination of digital piano and electronic keyboard features let you perform perfectly. We hope this skilfully built digital piano will able to explore your creativity, and brings you unlimited happiness and music enjoyment. Before you use the piano, we recommend you to read through this manual. Please keep this instruction manual for future reference.

## Precautions

Please read the following carefully before use:

- Do not expose the piano to high temperature, direct sunlight and excessively dusty places.
- Do not place the piano too close to other electrical appliances such as television and radio. It may cause interference.
- Do not place the piano to excessive humid area. Avoid putting container with liquid on top of the piano for preventing the damage of the internal parts of the piano by flowing liquid.
- Always unplug AC cord by gripping the plug firmly, but not pulling on the cable.
- Do not apply excessive force to the switches and buttons.
- When the piano is not in use or in the time of thunderstorm, please disconnect the power supply.
- Avoid adjusting the volume level to the maximum or to the levels that you feel uncomfortable, we recommend you to limit the volume level to two-third of the max for preventing the damage of auditory sense
- Unplug the power cable before cleaning the piano. Do not connect or disconnect the power cable with a wet hand.
- Check and clean the power plug periodically.
- To avoid damage to the piano and other devices to which it is connected, turn the power switches of all related device off prior to connecting or disconnecting cables.
- Clean the piano and remove the dust with a dry soft cloth or a slightly damp cloth.
- Never use cleaners such as thinner or alcohol. To prevent any damage on the surface of the LED display, please use lens cleaning tissue to clean the display.
- If the piano cable is damaged, please do not use the piano. Otherwise it may cause fire or electrical hazard.
- In case of malfunction due to improper handling the piano, please switch off and on again after 30 seconds.
- Do not attempt to disassemble or repair the piano by yourself. If the piano does not work properly, please contact the approved repairer.
- The piano should not be exposed to dripping or splashing. Do not place any object filled with liquids on the piano.

# Contents

<b>Digital Piano Set-up Guide</b> .....	<b>3-5</b>
<b>General Guide</b> .....	<b>6-7</b>
<b>The Connectors</b> .....	<b>8</b>
- Using the AC power jack.....	8
- Using Headphones.....	8
- Using the MIDI OUT jack.....	8
<b>Operation</b> .....	<b>9-13</b>
1. Power Switch & Volume.....	9
2. Voice/Dual Voice .....	9
3. Metronome .....	9
4. DSP (Digital Signal Processor) .....	10
5. Transpose .....	10
6. Tempo.....	10
7. Touch Response.....	10
8. Record & Playback .....	11-12
9. Demo Song .....	12-13
10. Foot Pedals .....	13
<b>MIDI</b> .....	<b>14</b>
- What is MIDI? .....	14
- What you can do with MIDI? .....	14
<b>Specifications</b> .....	<b>15</b>
<b>Voice List</b> .....	<b>16</b>
<b>Demo Song List</b> .....	<b>16</b>

# Digital Piano Set-up Guide

1. Open the package, and check whether the following parts are available:

- |                        |   |
|------------------------|---|
| 1. Piano body          | 6. Foot pedal unit                      |
| 2. Music stand         | 7. Hand screw (4 pcs.)                  |
| 3. Right leg component | 8. Screws (8 pcs.)                      |
| 4. Left leg component  | 9. Screw caps (8 pcs.)                  |
| 5. Back panel skirt    | 10. Power cable stabiling hook (2 pcs.) |

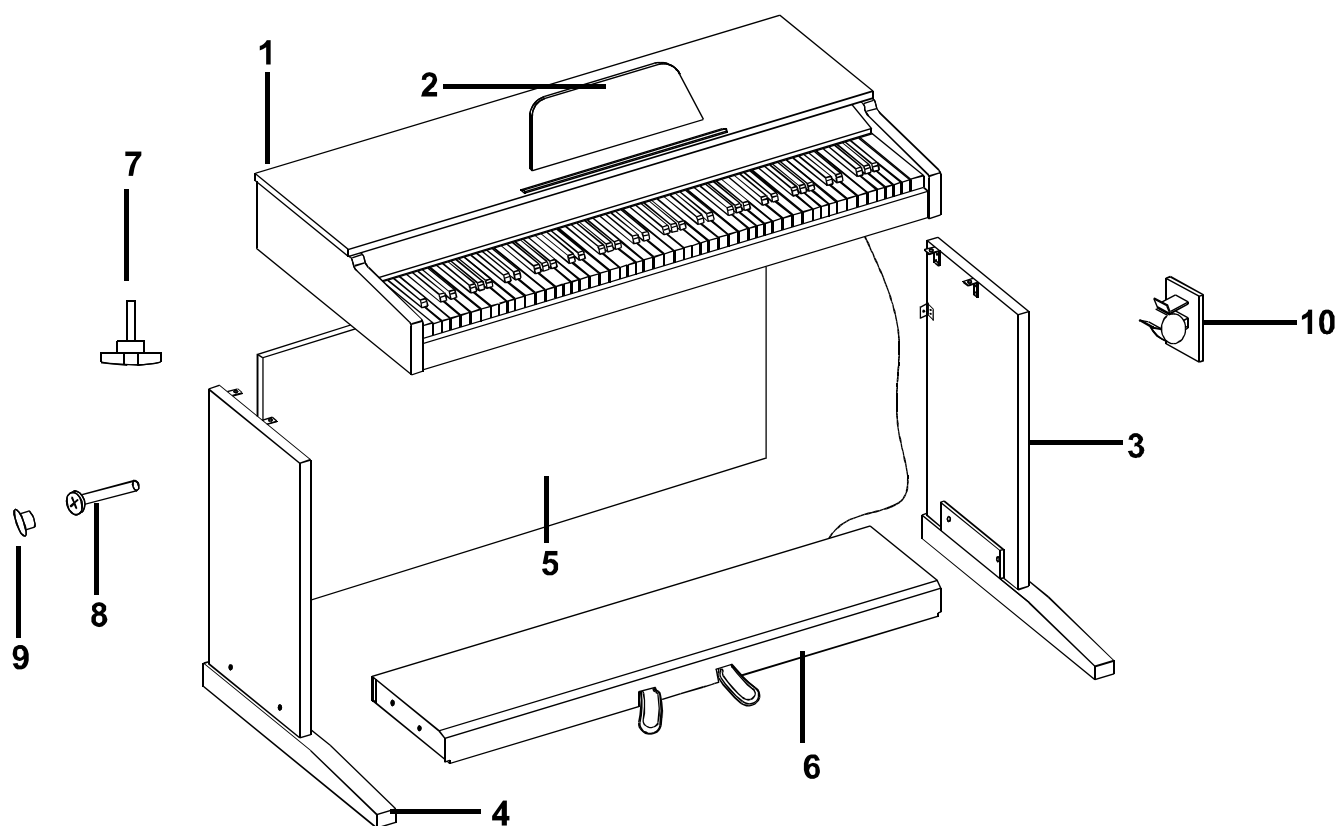

# Digital Piano Set-up Guide

2. Follow the illustration below and finish off the set-up procedures.

- A. Put the foot pedal unit(6) in between the left and right legs components (3&4) . Use 4 pieces of screws (2 on each side) to stable the legs onto the foot pedal unit.  
(Make sure the direction of the placement is correct before screwing)

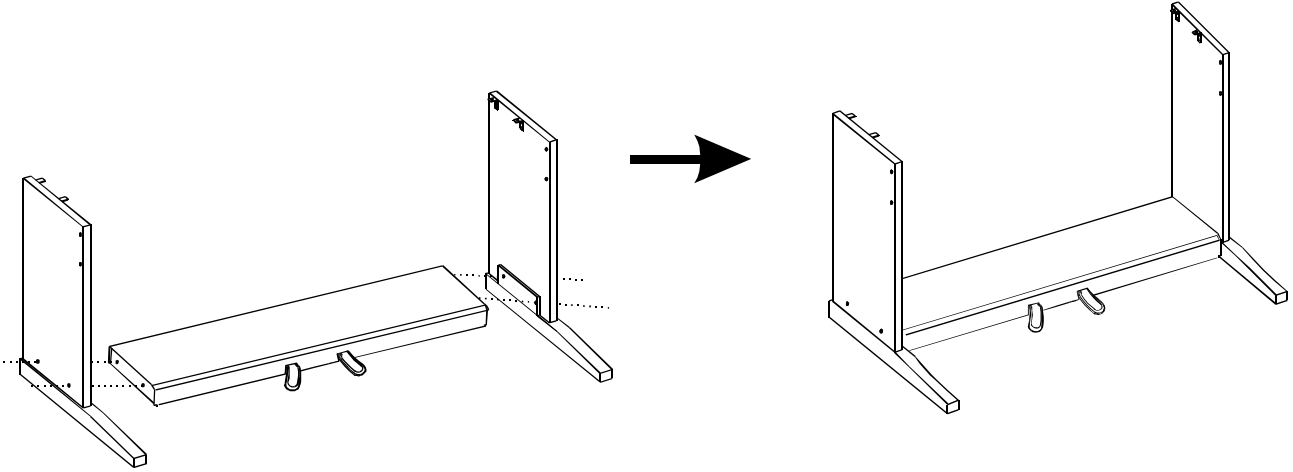

- B. Use 4 pieces of screws (2 on each side) to tighten the back panel skirt (5) onto the finished assembly in Part A.

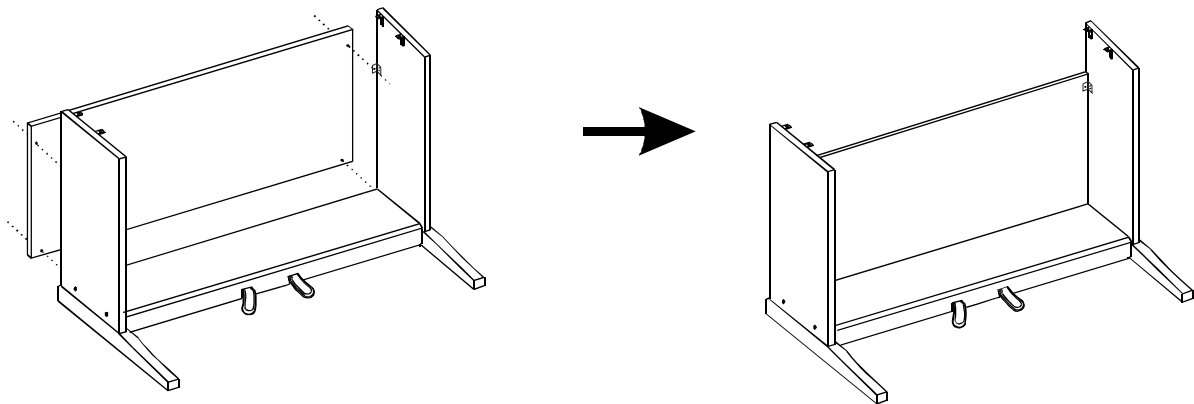

# Digital Piano Set-up Guide

- C. Put the piano body(1) on the top of the finished assembly in part B. Use 4 pieces of hand screws to stable afterward.

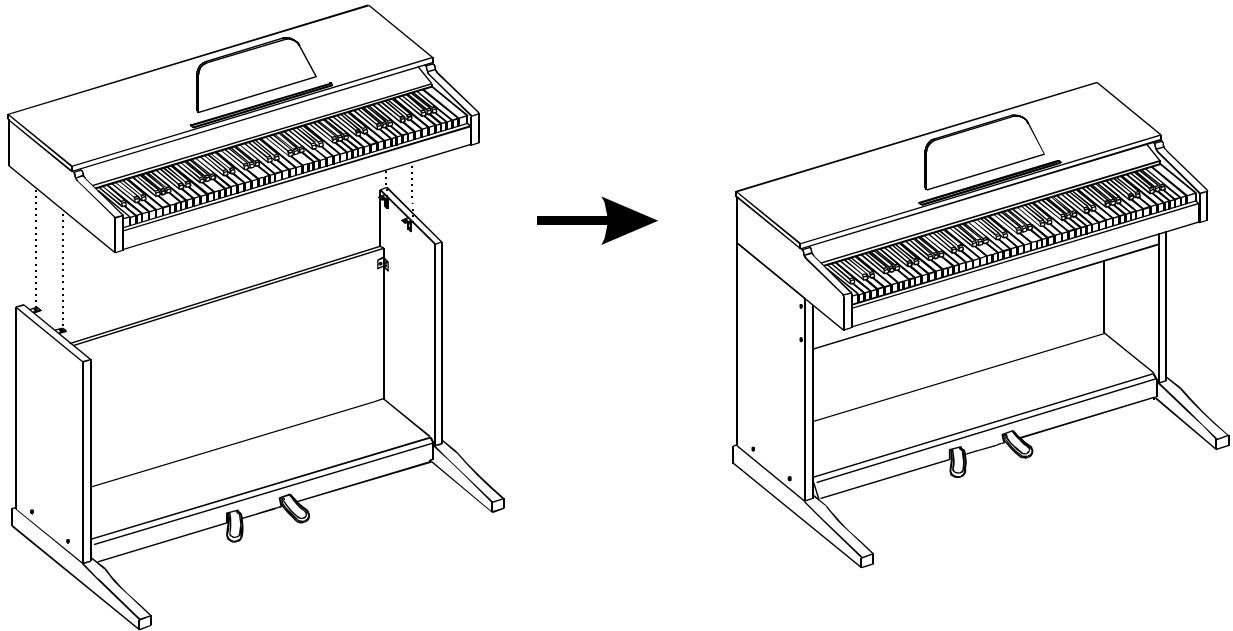

- D. After the initial set-up, stick the cable stabiling hook(10) on the internal side of the leg component (see the below illustration for reference).

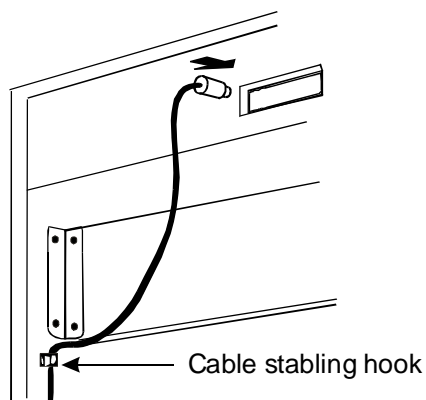

# General Guide

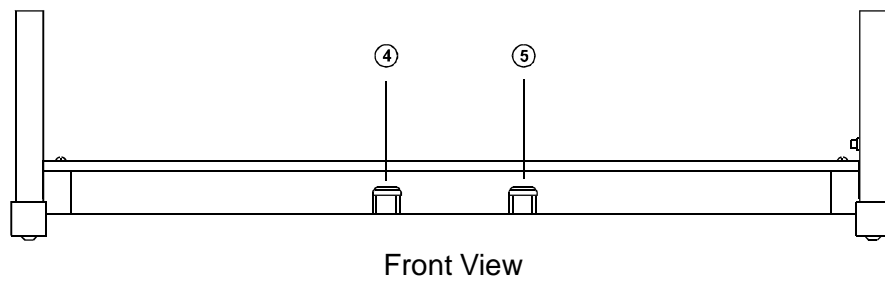
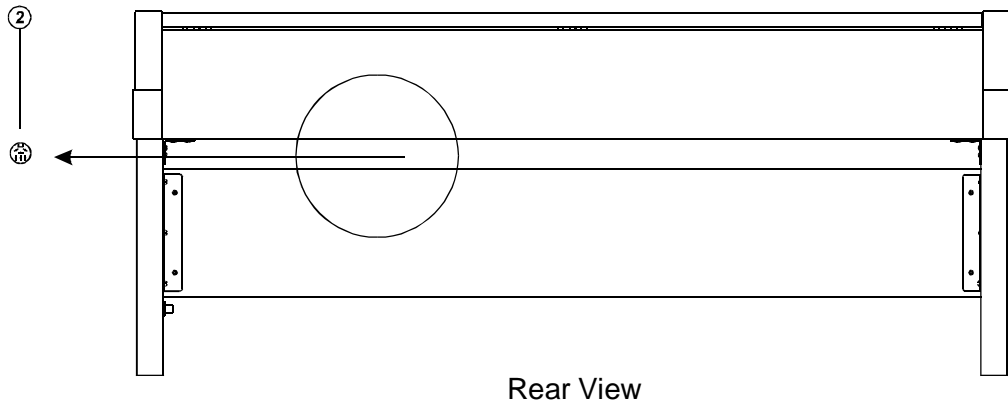
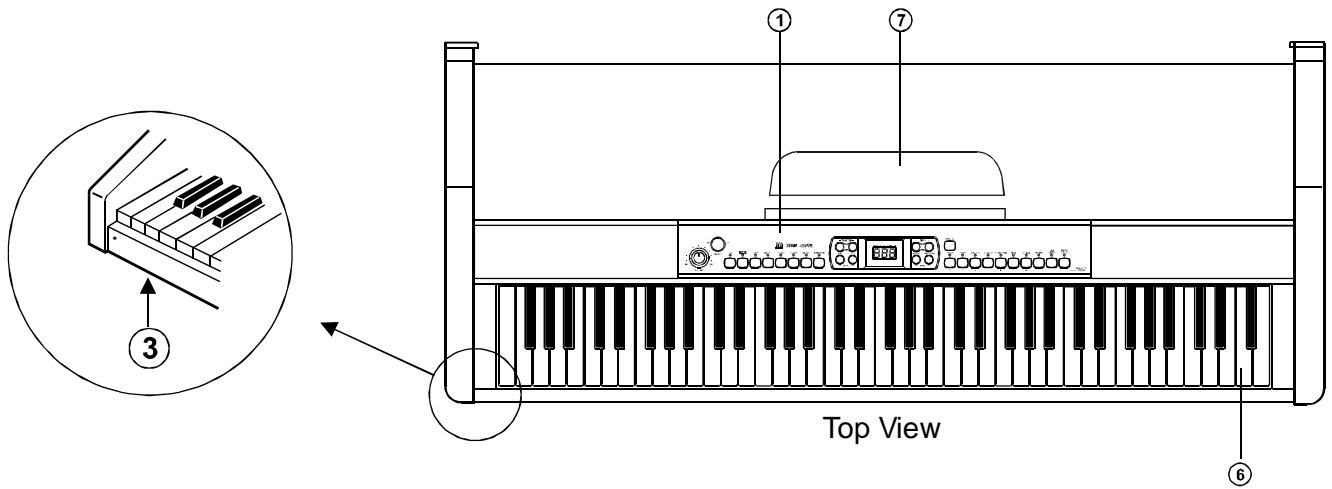

- ① Control Panel
- ② MIDI OUT Jack
- ③ Headphones Jack

- ④ Soft Pedal
- ⑤ Sustain Pedal
- ⑥ Piano Keyboard
- ⑦ Music Stand

# General Guide

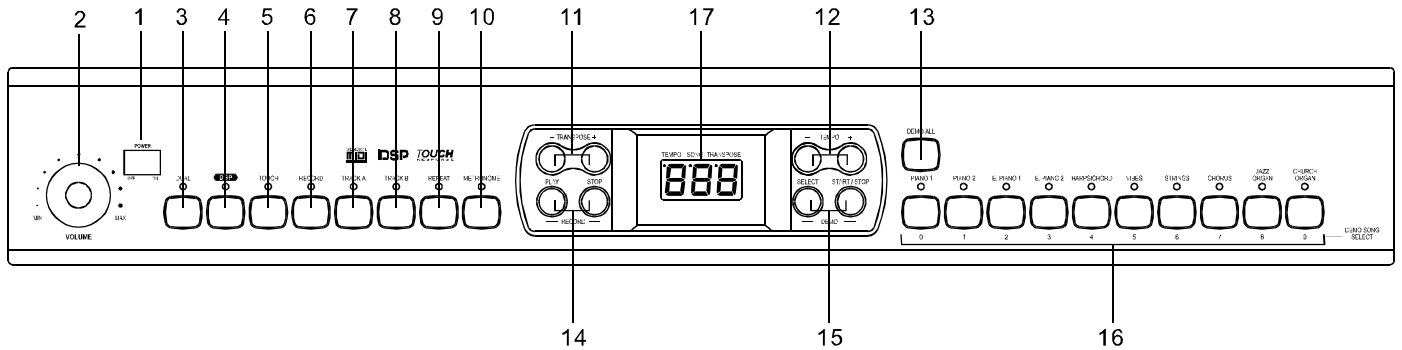

- ❶ POWER SWITCH
- ❷ MASTER VOLUME
- ❸ DUAL
- ❹ DSP
- ❺ TOUCH
- ❻ RECORD
- ❼ TRACK A
- ❽ TRACK B
- ❾ REPEAT
- ❿ METRONOME
- ⓫ TRANPOSE +/-
- ⓬ TEMPO +/-
- ⓭ DEMO ALL
- ⓮ RECORD
  - PLAY
  - STOP
- ⓯ DEMO
  - SELECT
  - START/STOP

- ⓰ VOICE TYPE & DEMO SONG SELECT
  - 0 - PIANO 1
  - 1 - PIANO 2
  - 2 - E.PIANO 1
  - 3 - E.PIANO 2
  - 4 - HARPSICHORD
  - 5 - VIBES
  - 6 - STRINGS ENSEMBLE
  - 7 - CHORUS
  - 8 - JAZZ ORGAN
  - 9 - CHURCH ORGAN
- ⓱ LED
  - TEMPO
  - SONG
  - TRANPOSE

# The Connectors

## Using the AC power jack

1. Ensure the piano is turned off when connecting and disconnecting the power.



2. Turn the volume switch anti-clockwise to reach the minimum volume level.

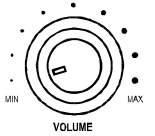

3. Plug the power cable into an AC power outlet.

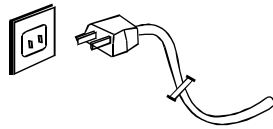

4. If you have done the above procedures, you are now safe to turn on the piano.

**Caution:** • When the piano is not in use or during a thunderstorm, disconnect the power for safety sake.

## Using Headphones

There are two headphones jacks on the left underneath the piano body.

When an optional set of stereo headphones is connected with the headphones jack 2, the sound from speakers will switch off automatically resulting in only the sound from headphone to be heard.

When jack 1 is connected with the stereo headphones, the sound can be heard from both headphones and speakers of the piano.

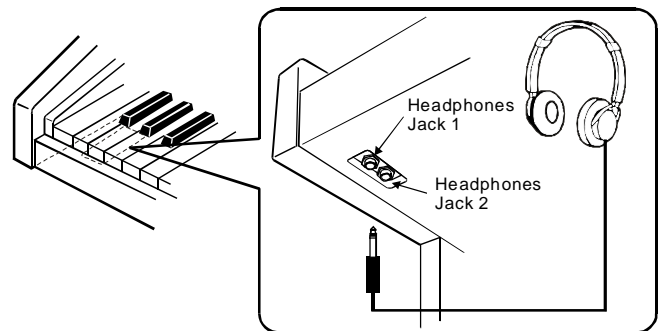

**Caution:** • Never use the headphone with high volume, as it may damage your sense of hearing.  
• To prevent the damage of the speakers, ensure that the volume is set to the minimum level before connecting the power and other devices.

## Using the MIDI OUT Jack

MIDI stand for Musical Instrument Digital Interface. MIDI is a world wide standard that makes it possible for various electronic musical instruments and other devices.



**MIDI OUT:** Data produced by the Digital Piano is transmitted to other MIDI instruments via MIDI from this terminal.

# Operation

## 1. Power Switch & Volume

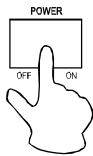

1. Turn the **POWER** switch on.  
The LED display lightens up.



2. Use the volume control switch to adjust the volume to your desired level

- Caution:**
- If the LED display has not lightened up after you turned on the piano, please check the power supply.
  - If the piano is silent, the volume may be adjusted to its minimum level.
  - Although Mains switch is in OFF position, the piano is not disconnected from the power supply completely!

## 2. Voice/Dual Voice

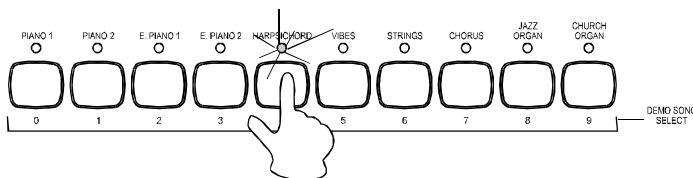
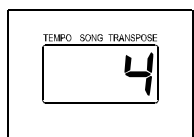

- Select a voice by pressing one of the [VOICE TYPE] button, the corresponding indicator will lighten up and the number of the selected voice will appear on the LED.

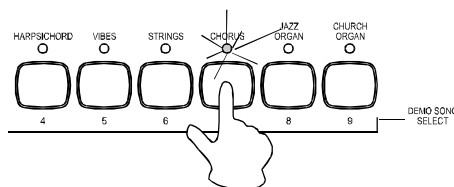
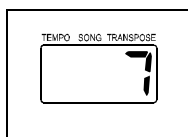

- Press the [DUAL] button to enter the Dual Voice mode, then select the second voice by pressing a [VOICE TYPE] button.
- To quit the Dual Voice mode, press the [DUAL] button again.
- While recording, Voice 2 will turn off automatically.

## 3. Metronome

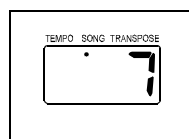
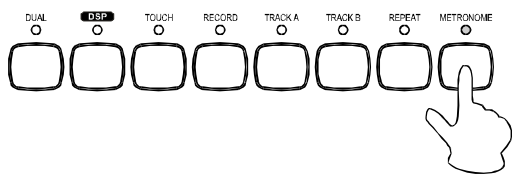

- Press the [METRONOME] button to turn on/off the metronome function.
- You cannot use the metronome function when the DEMO song is playing.
- To turn off the metronome, press the [STOP] button.

# Operation

## 4. DSP (Digital Signal Processor)

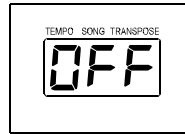
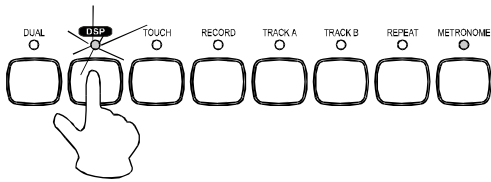

- Press the [DSP] button to turn on/off the DSP. The status will appear on the LED.

## 5. Transpose

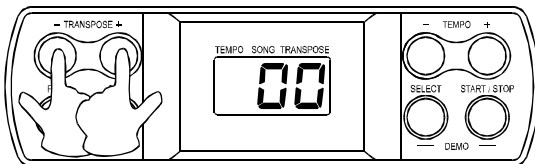
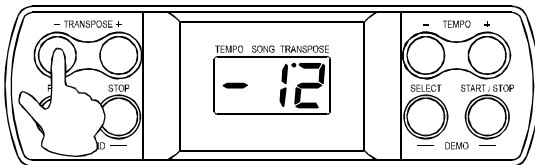

- The Transpose function allows you to change the pitch of the instrument in semi-tone steps, up to a maximum setting of 12 semitones above or below standard pitch.
- To restore the normal Transpose position, press both the +/- buttons simultaneously.

## 6. Tempo

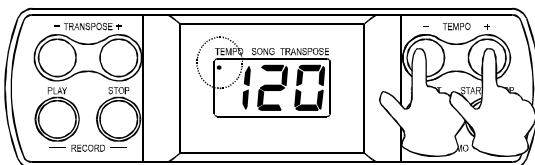
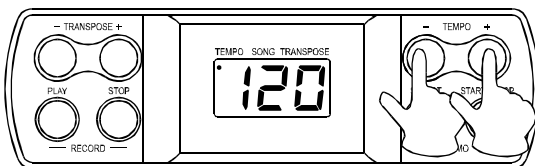
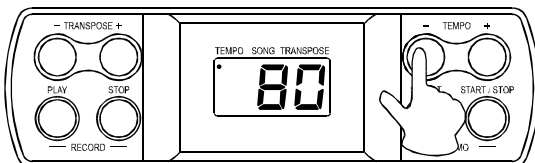

- You can speed up or slow down the tempo of a song or metronome by pressing the [TEMPO +/-] buttons.
- To restore the default tempo, press both the +/- buttons simultaneously. When you press both the +/- buttons when the song/metronome is stopping, the tempo will return to 120.
- When you are adjusting the tempo, the tempo indicator will appear on the display.

# Operation

## 7. Touch Response

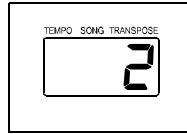
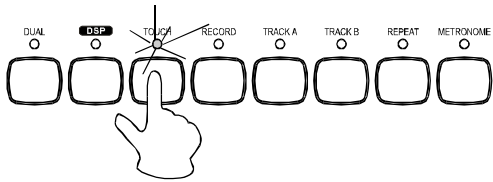

- There is touch response function and it is a default setting.
- Press the [TOUCH] button to adjust the touch response level in the range of 1 to 3. 2 is the default level.
- To turn off the touch response function, press the [TOUCH] button repeatedly until "OFF" appearing on the display.

## 8. Record & Playback

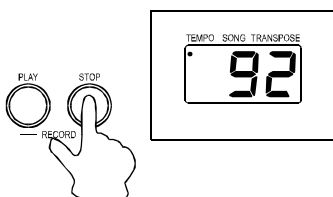
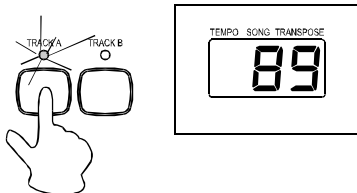
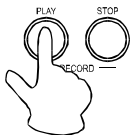
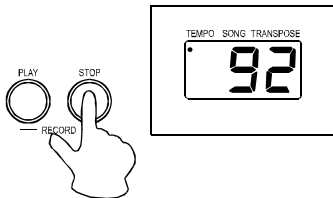
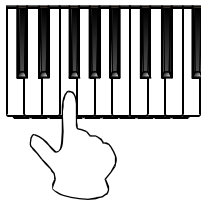
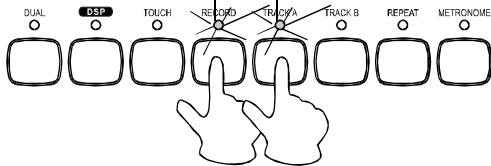

- **Record**
  - Press the [RECORD] button to record. The indicator of record lightens up.
  - There are 2 tracks for recording. They are track A and track B. Select and press the [TRACK A] or [TRACK B] button to save your recording.
  - To remove the recorded data and record again, press the [RECORD] and [TRACK A] or [TRACK B] simultaneously. Their indicators lighten up and flash.
  - Play a key on the keyboard to start recording.
  - To stop recording, press the [STOP] button.
- **Playback**
  - Select and press the track you want to playback. Its indicator will lighten.
  - Press the [RECORD-PLAY] button to start playing back the track.
  - To stop the playback, press the [RECORD - STOP] button .

# Operation

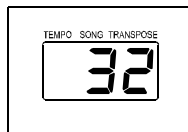
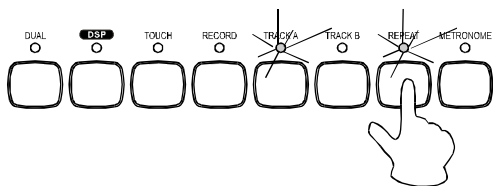

- **Repeat the playback**

During the playback, press the [REPEAT] button to set the point of beginning that you want to listen, "r-A" will appear on the display, then press the [REPEAT] button again to set the end point of the playback, "r-B" will appear on the display and the recorded song will playback repeatedly.

## 9. Demo Song

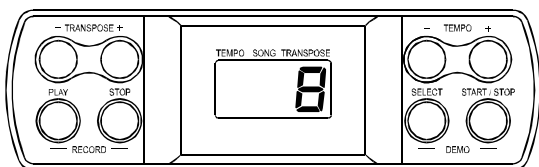
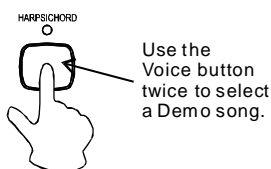
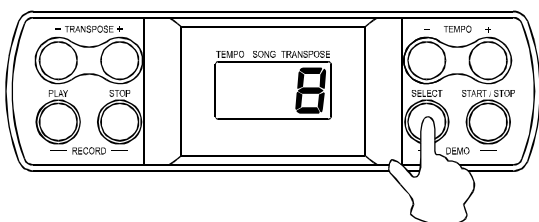

- **Select a Demo song**

- Hold the [SELECT] button.

- The number of the current demo song will appear on the display.

- Use the Voice Select buttons (0-9) to select your desired demo song. You must enter a 2-digit number (00-19).

- **Play the demo songs in sequence**

- Press the [DEMO ALL] button to start playing the demo songs in sequence. To stop the demo songs, press the [DEMO ALL] or [START/STOP] button.

- When the demo songs is playing, you can not change it to another one immediately.

- **Select a track of the demo song**

- While the demo song is playing, you can deactivate the corresponding track by pressing the [TRACK A] or [TRACK B] button.

- No sound to be played, if two tracks are deactivated.

- Press the track button again to play the demo song.

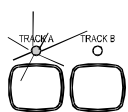

# Operation

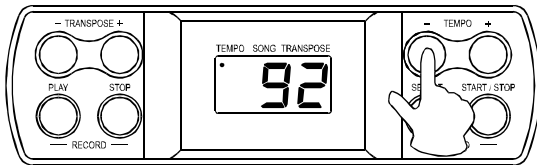
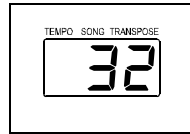
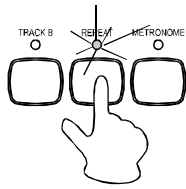

## 10. Foot pedals

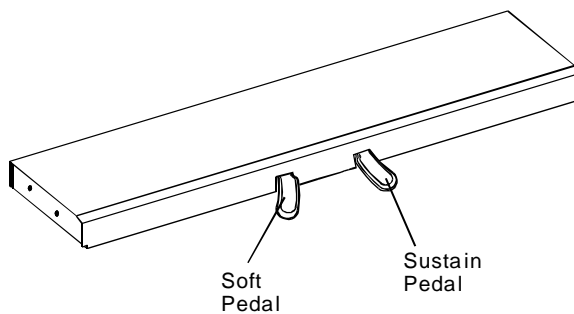

- **Repeat the demo song**
- When a demo song is playing, press the [REPEAT] button to set the point of beginning that you want to listen. "r-A" will appear on the display, then press the [REPEAT] button again to set the end point of the playback. "r-B" will appear on the display and the selected section of the demo song will playback repeatedly.
- This function does not work after pressing the [DEMO ALL] button and its songs are playing.
- **Adjust the tempo of demo song**  
When a demo song is playing, you can adjust its tempo by pressing the [TEMPO +/-] buttons.
- The piano has 2 foot pedals, soft pedal and sustain pedal.

# MIDI

The MIDI OUT terminals, which is located at the rear panel of the unit.  
The following shows the description of MIDI and the steps of using MIDI function.

## What is MIDI?

MIDI stand for Musical Instrument Digital Interface. MIDI is a world wide standard that makes it possible for various electronic musical instruments and other devices, such as computers, to "communicate with each other".

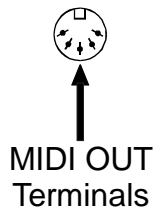

The keyboard is equipped with one type of MIDI terminals, is located on the rear panel.

- **MIDI OUT**

Data produces by the keyboard, is transmitted to other MIDI instruments via MIDI from this terminal.

## What you can do with MIDI?

- Record a data by using the Auto Accompaniment on an external sequencer .  
After recording, you can edit the data with the sequencer.

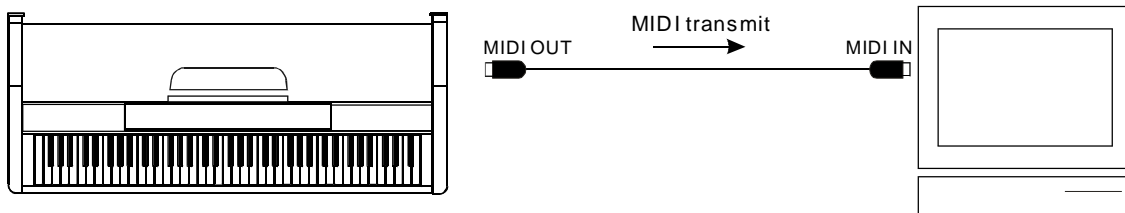

- Play music from another keyboard .

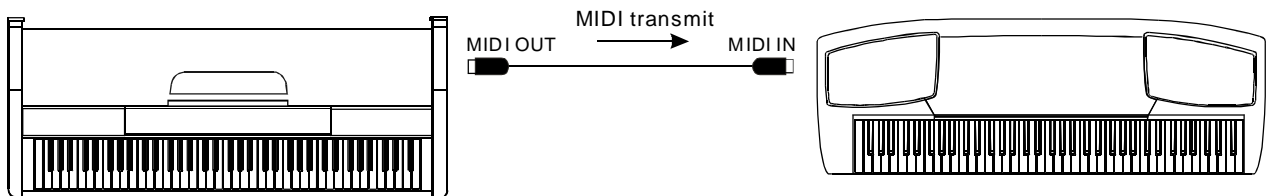

# Specifications

<b>Keyboard</b>	88 hammer action keys
<b>Voice</b>	10 Voices
<b>Demo Song</b>	20 Demo Songs
<b>Display</b>	LED
<b>Switch and Buttons</b>	POWER SWITCH, VOLUME SWITCH, DUAL, DSP, TOUCH, RECORD, TRACK A, TRACK B, REPEAT, METRONOME, TRANSPOSE +/-, TEMPO +/-, DEMO ALL, RECORD - PLAY/STOP, DEMO - SELECT/ START/STOP, VOICE SELECT 0-9
<b>Transpose</b>	±12 semi tones
<b>Pedals</b>	Soft, Sustain
<b>Touch Response</b>	Hard, Medium, Soft, Off
<b>Connectors</b>	AC POWER, HEADPHONES, MIDI OUT, PEDALS
<b>Speaker</b>	8ohm 25w x 2
<b>Dimension</b>	1380 x 520 x 830mm
<b>Weight</b>	62kg

## Voice List

No	Name of Voice	Name of Voice on Panel
0	Acoustic Grand Piano	PIANO 1
1	Bright Acoustic Piano	PIANO 2
2	E. Piano 1	E. PIANO 1
3	E. Piano 2	E. PIANO 2
4	Harpsichord	HARPS.
5	Vibraphone	VIBES
6	Strings Ensemble	STRINGS
7	Chorus	CHORUS
8	Jazz Organ	JAZZ ORGAN
9	Church Organ	CHURCH ORGAN

## Demo Song List

00	GIPSY RONDO
01	TOCCATA
02	MAPLE LEAF RAG
03	THE STING
04	MINUET 1
05	SPRING
06	VOICES OF SPRING
07	HALELUYA
08	BABY ELEPHANT WALK
09	WEDDING MARCH
10	ANDANTE [SURPRISE] SYMPHONY
11	TURKISH MARCH
12	SONATINA MOVEMENT
13	MINUET 2
14	THE LAST ROSE OF SUMMER
15	CLELITO LINDO
16	BEAUTIFUL DREAMER
17	WEBER'S LAST THOUGHT
18	JOY TO THE WORLD
19	TRINITY