

ASSEMBLY INSTRUCTIONS

Caution !

Watch your fingers when adjusting clamps. They may become pinched resulting in injury.
Be careful around pipe ends, inside the pipe and screw ends. Metal shavings, etc. May injure your fingers.

Inside This Package

Before assembly, please make sure that all the items listed below are present.

[CYMBAL 3PCS] box

Cymbal Pad x 3



[BASS DRUM PEDAL] box

Kick Pad



Foot Pedal

Beater



[DRUM PADS] box

Drum Pad x 2



Metal Rod x 2



[DRUM PADS] box

Drum Pad x 2



Metal Rod x 2



[ACCESSORIES] box

Cymbal holder (S)



Drumstick x 2



Hexagon Key (5mm)



Drum Key



Metal Rod



Connecting Cable x 9



Instruction Manual

Assembly Instructions

AC Adaptor

[HI-HAT PEDAL] box



[DRUM MODULE] box



Cymbal holder (L)



Cymbal holder (L)



Side Arm (L1)

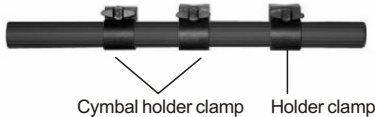

Side Arm (L2)

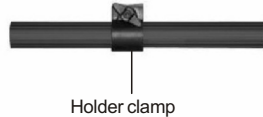

Side Arm (R)

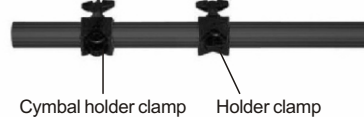

Pillar (L)

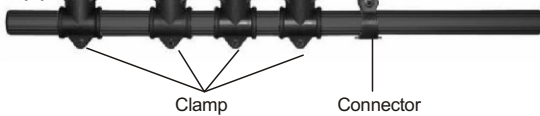

Pillar (R)

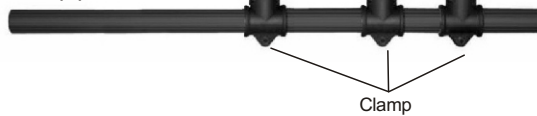

Center Pipe (1)

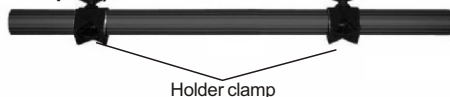

Center Pipe (2)



Leg (L)

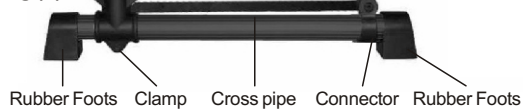

Leg (R)



Assembly

1 Setting up the frame of the digital drum set

- [1] Attach the Pillar (L) to the clamp on the Leg (L).
- [2] Using the drum key, tighten the screws on the clamp.
- [3] Remove the screw attached to the connector.
- [4] Attach the cross pipe to the connector.
- [5] Reattach the screw into the connector
- [6] Tighten the screw on the connector.
- [7] Attach the Pillar (R) to the clamp on the Leg (R).
- [8] Tighten the screws on the clamp.
- [9] Attach Center Pipe (1) to the clamp on the Leg (L).
- [10] Tighten the screws on the clamp.
- [11] Attach Center Pipe (2) to the clamp on the Leg (L).
- [12] Tighten the screws on the clamp.
- [13] Attach the Right Leg Assembly to the Center Pipe (1) and Center Pipe (2)
- [14] Tighten the screws on the clamp.
- [15] Tighten the screws on the clamp.

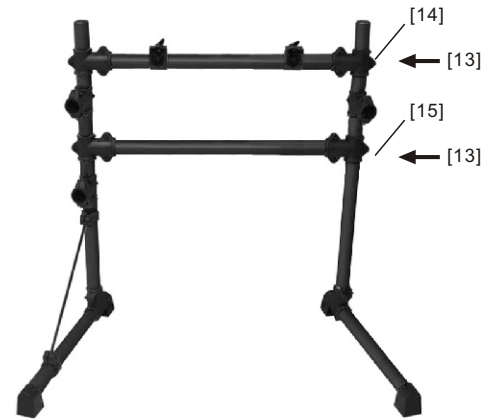
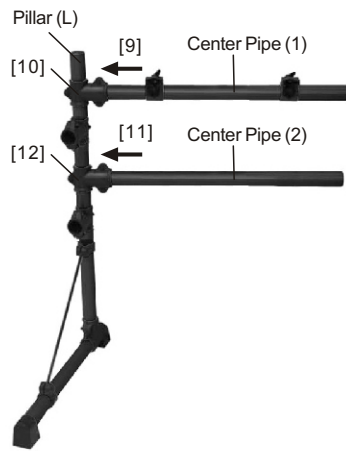
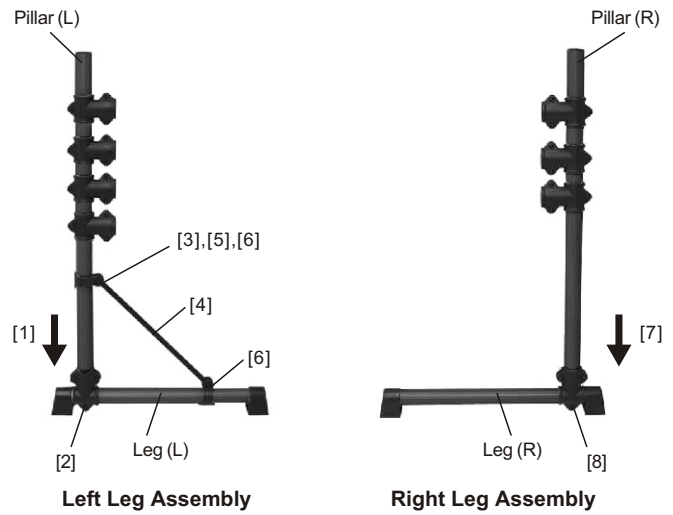

- [16] Attach the Side Arm (L1) to the clamp on the Pillar (L) .
- [17] Tighten the screws on the clamp.
- [18] Attach the Side Arm (L2) to the clamp on the Pillar (L).
- [19] Tighten the screws on the clamp.
- [20] Attach the Side Arm (R) to the clamp on the Pillar (R)
- [21] Tighten the screws on the clamp.

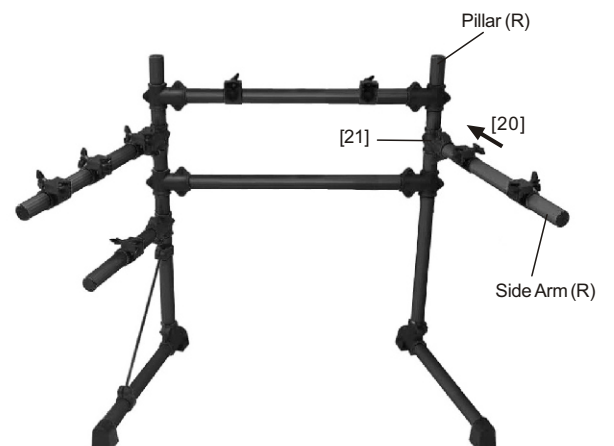
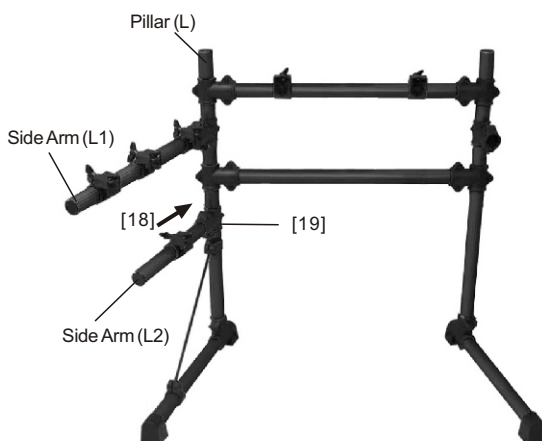
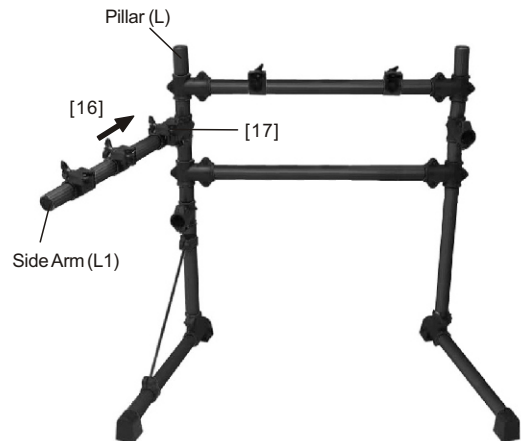

2 Attaching the drum pads

- [1] Loosen the wing nuts on the drum pads .
- [2] Remove the Metal Rods.
- [3] Reattach the Metal Rods to the drum pads.
- [4] Tighten the wing nuts securely.

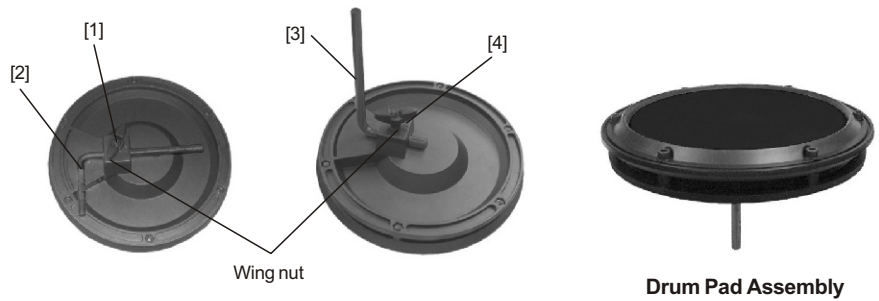

- [5] Attach the drum pads assemblies to the holder clamps and adjust their position, then tighten the wing nuts on the Holder clamps.

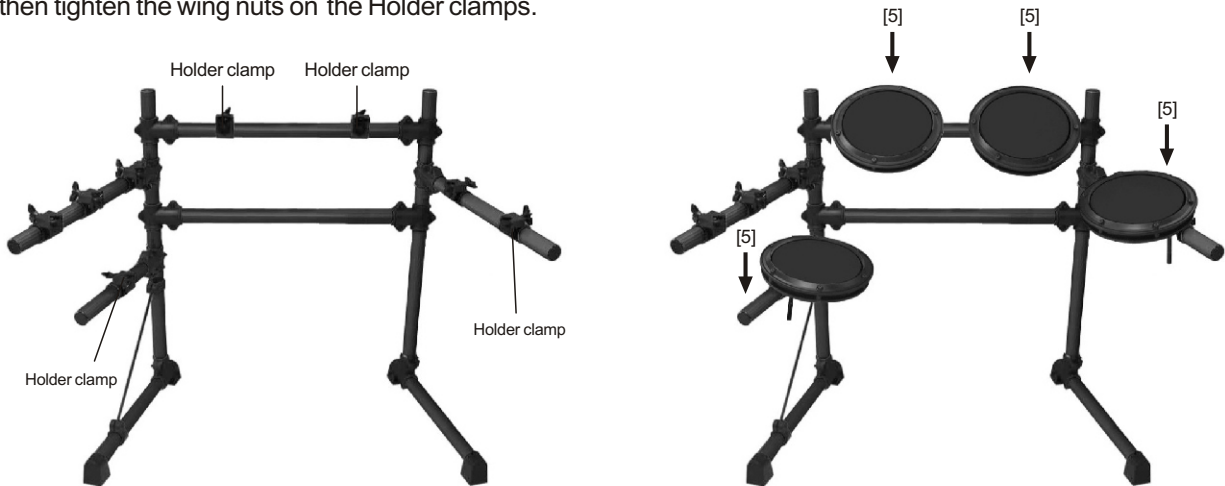

3 Attaching the cymbal pads

- [1] Attach the Cymbal holders to the Holder clamps on the Side Arms.
- [2] Tighten the wing nuts on the Holder clamps.
- [3] Remove the wing nut and the felt washer of each Cymbal holders.
- [4] Attach the Cymbal pads to the cymbal holders.
- [5] Reattach the felt washer and wing nut, tighten the wing nut of each cymbal holders.

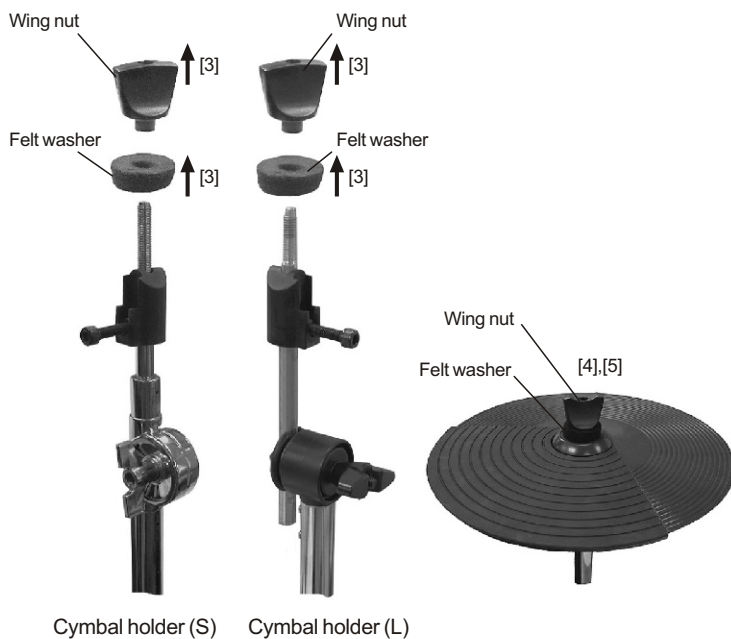
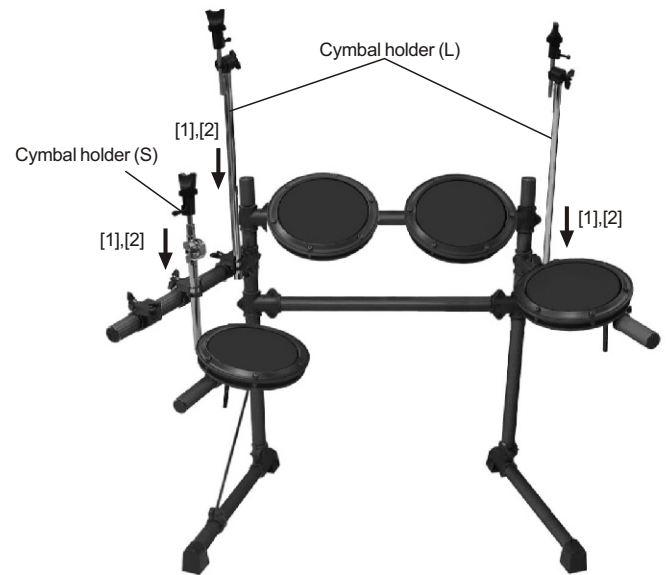

4 Attaching the Drum Module

- [1] Attach the Metal Rod to the Drum Module.
- [2] Tighten the wing screw securely on the Drum Module.
- [3] Attach the Metal Rod to the Holder clamp on the SideArm (L1) and adjust the position.
- [4] Tighten the wing nut on the Holder clamp.

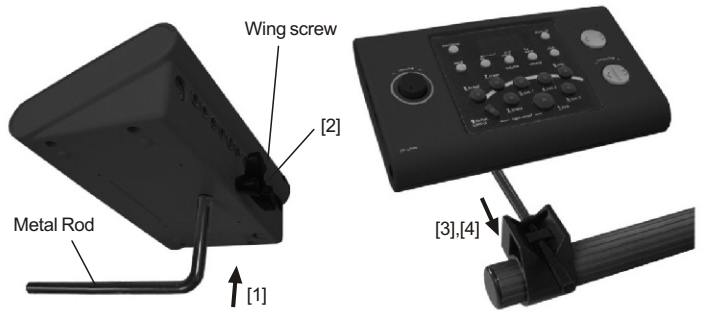

5 Attaching the Kick Trigger

- [1] Attach the Rod to the holders.
- [2] Attach the Kick Pedal to the Kick Pad.
- [3] Tighten the wing screw on the Kick Pedal.
- [4] Loosen the screw.
- [5] Attach the Beater to the Kick Pedal
- [6] Position the Beater from the center of the pedal, tighten the screw

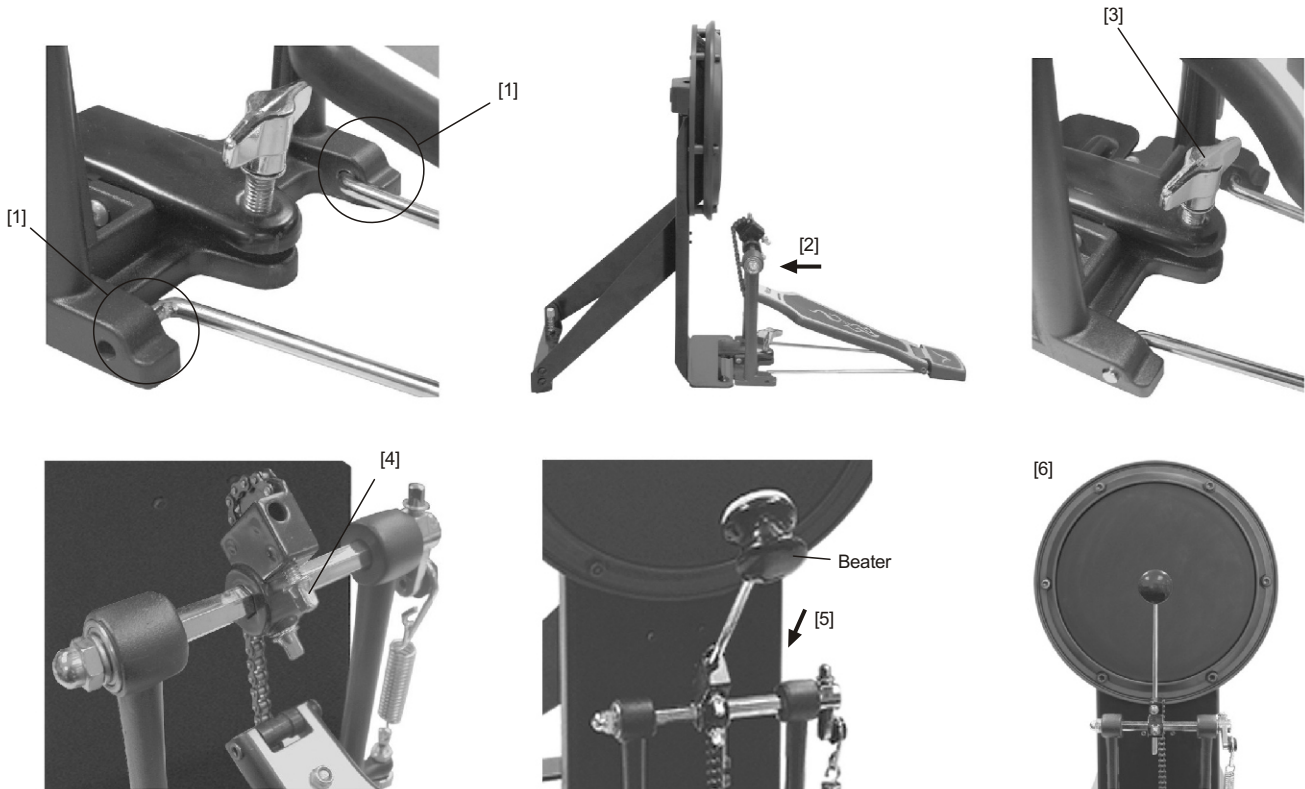

6 Setup Example

